

TABLE OF CONTENTS

SAFETY PROCEDURE	3
DELIVERY INSPECTION	3
OPERATION	3
MAINTENANCE	4
TROUBLE SHOOTING	5
WARRANTY CLAIMS PROCEDURE	5
PARTS DIAGRAMS	6-19
STANDARD PUMP AND HANDLE ASSEMBLY	6-7
L50 & L60 MODELS - FRAME ASSEMBLY	8-9
L50M & L50MU MODELS - FRAME ASSEMBLY	10-11
L50M & L50MU (4-WAY) MODELS - FRAME ASSEMBLY	12-13
HEAVY DUTY PUMP AND HANDLE ASSEMBLY	14-15
L80 & L100 MODELS - FRAME ASSEMBLY	16-17
OPTIONAL TANDEM LOAD ROLLER AND BRAKE ASSEMBLY	18-19

**SAFETY SHOES**

Always wear safety shoes when working with hand pallet trucks.

PROTECTIVE GLASSES

When assembling or dismantling a hand pallet truck, protective glasses must be worn to avoid personal injury.

**OPERATOR'S RESPONSIBILITY**

While operating a hand pallet truck always wear safety equipment and operate in a responsible manner to ensure a safe work area.

SAFETY PROCEDURES

- Never overload your hand pallet truck. Stay within rated capacity.
- Distribute the load evenly on the forks. Do not concentrate loads at one point or load one fork more than the other.
- Never put your feet, hands or any other body part under the frame assembly.
- Do not allow your hand pallet truck to drop from one level to another. Even a drop of 1" (25mm) more than doubles the effective load momentarily and results in a "Shock" which can bend or break components.
- Always ensure load is stable before moving to eliminate opportunity for load shift.
- When not in use, forks should be fully lowered to avoid injury.

DELIVERY INSPECTION

Visually inspect hand pallet truck frame components and hydraulic unit for damage during shipping by carrier. If damage is evident, notify delivering carrier immediately and file necessary claims. Test the hand pallet truck pump for operation. **If the hydraulic pump does not respond to movement of the handle, an air lock may have developed during shipping.** To remedy this, pull and hold the release lever then operate the pump several times. If the pump still fails to respond, see the trouble shooting guide on page 5.

OPERATING INSTRUCTIONS

- To raise load, push down on finger tip control. Pump handle to raise load from floor.
- To lower load, pull up on finger tip control.
- For free handle movement, place finger tip control in neutral position.

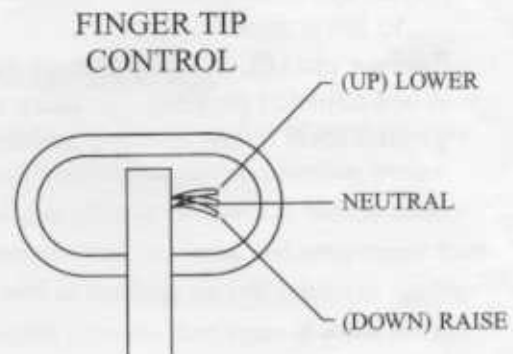

NOTE:

The neutral position disengages the pump from the lifting mechanism. This frees the handle, which makes pulling loads much easier. Also the pump is not being subjected to shock pressures while the truck is in motion.

MAINTENANCE

Lubrication

All pivot points are equipped with permanently lubricated bushings and bearings. To increase bearing life, it is recommended that a few drops of light machine oil be applied at each pivot point every 6 months.

The main bearing in the thrust plate is equipped with a grease zerker. This should be greased every 6 months.

Hydraulic system

Your hydraulic system is maintenance free. Do not add hydraulic oil unless there is, or has been a leak. Use Sunoco Sunvis 832 oil or equal. Any other oils, fluids or solvents can damage your hydraulic system. If additional oil is required, position forks in lowered position. Remove oil level plug (PL-10267). Refill with hydraulic oil to plug hole level. Replace oil level plug.

Push bar linkage adjustment

If the forks do not raise evenly at the tips, or the roller levers begin to drag on the floor, the following adjustment is necessary:

- Turn the hand pallet truck over so that the under side of the forks are accessible.
- Remove one split pin (PL-10228) with 1/8" punch.
- Remove pin (PL-10227) from bracket.
- Adjust eye bolts (PL-10226). Turn counter-clockwise to raise fork tips and clockwise to lower fork tips.
- Replace pin (PL-10227) through eye bolt and replace split pin (PL-10228).
- When adjusted properly the forks should be 3" (L50 Model) low height from ground level in the lowered position.

TROUBLE SHOOTING

Condition	Possible cause	Action
-Pump does not lift load	-An air lock in the hydraulic system	-Pull up on finger tip control and hold while pumping handle several times to bleed air from system
-Lifting, neutral, and lowering does no function properly	-Chain anchor adjustment required	-Turn nut (PL-10271) on chain anchor clockwise until pumping action while in neutral does not raise forks
-Forks raise and sink with pump action	-Dirt or foreign particle caught in valve ball seat	-Pull up on finger tip control and hold while pumping handles several times.
-Pump does not lift load to complete raised height	-Pump is low on oil due to oil leak	-Refer to procedure for adding hydraulic oil in maintenance section
-Forks are not lowering all the way	-Push bars need adjustment	-Refer to push bar linkage adjustment in the maintenance section.

WARRANTY CLAIM PROCEDURE

In order to claim for warranty, you must supply the truck serial number, as well as date of purchase. Any truck used under adverse conditions, such as fish, meat or poultry processing plants, tanneries, freezer applications, or any other application where the unit is operating in water or subjected to fluid or chemicals, is NOT covered under any warranty. A freezer special truck prevents the frame and components from rusting out prematurely. The hydraulic pump, all bearings, as well as bushings are still subject to condensation and therefore premature failure. Bent, twisted or misaligned forks are clear signs of abuse and are not covered under warranty. Effective March 1st 1997 please refer to Lift-Rite Warranty Claim procedure form, available from your Lift-Rite dealer.

STANDARD PUMP DIAGRAM

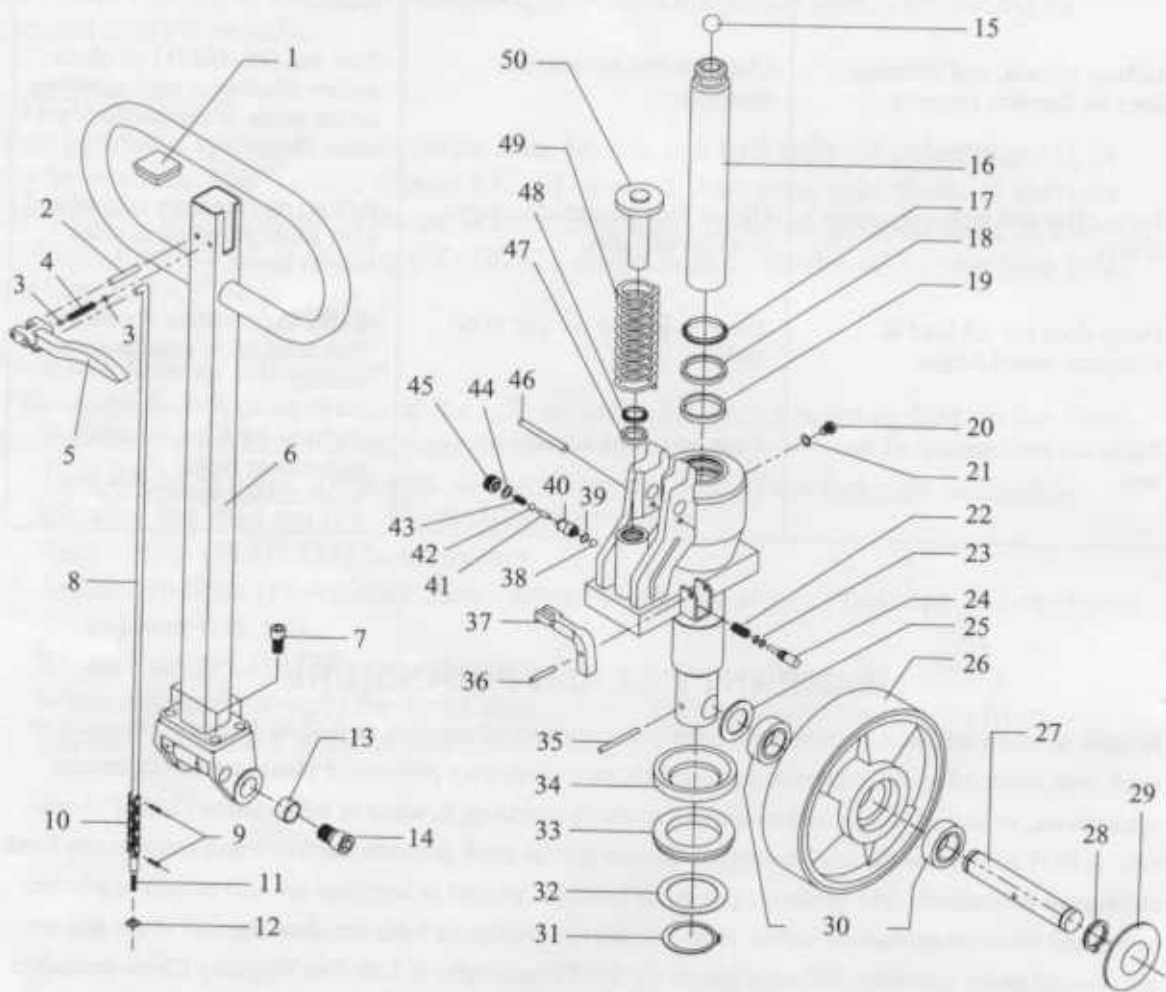

Item No.	DESCRIPTION	Part Number	Quantity	Item No.	DESCRIPTION	Part Number	Quantity
1	Handle Cap	PL10274E	1	36	Split Pin	PL10269	1
2	Split Pin	PL10274D	1	37	Lever	PL10268	1
3	Ball	PL10254	2	38	Ball	PL10261A	1
4	Spring	PL10274C	1	39	"O" Ring	PL10256	1
5	Control Lever	PL10274B	1	40	Ball Valve	PL10262	1
6	Outer Handle	PL10274	1	41	Split Pin	PL10263	1
	Complete Handle			42	Ball	PL10261	1
	Items 1-12	PL10276	1	43	Spring	PL10264	1
7	Bolt	PL10274F	4	44	"O" Ring	PL10265	1
8	Control Rod	PL10274A	1	45	Plug Bolt	PL10266	1
9	Rivet	PL10273	2	46	Split Pin	PL10277A	1
10	Chain	PL10272	1	47	Energized Seal	PL10252	1
11	Adjusting Bolt	PL10270	1	48	Wiper Ring	PL10251	1
12	Nut	PL10271	1	49	Handle return spring	PL10253	1
13	Bushing	PL10203A	2	50	Rear pump piston	PL10250	1
14	Allen Head						
	Shoulder Bolt	PL10275A	2				
15	Ball	PL10244	1				
16	Main Lift Piston	PL10243	1				
17	Wiper Ring	PL10245	1				
18	Energized Seal	PL10249	1				
19	Main Seal	PL10246	1				
20	Oil Filler Plug	PL10267	1				
21	Sealon	PL10259A	1		Replacement Kits		
22	Spring	PL10258	1		Pump Assembly		
23	"O" Ring	PL10259	2		5000 & 6000 lb	PL10277	
24	Release Valve	PL10260	1		Seal Kit	PL10278	
25	Spacer Washer	PL10239	2		Valve Kit	PL10279	
26	Steer Wheel				Complete Pump		
	Poly	PL10236B	2		Repair Kit	PL10280	
	Nylon	PL10236N	2				
	Steel	PL10236BS	2				
27	Axle	PL10240E	1				
28	Retaining Ring	PL10237	2				
29	Hub Cap	PL10236C	2				
30	Ball Bearing	PL10238D	4				
31	Retaining Ring	PL10235	1				
32	Thrust Washer	PL10234A	1				
33	Thrust Bearing						
	(5000 lb)	PL10234	1				
	Thrust Bearing						
	(6000 lb)	PH10234	1				
34	Pump Collar	PL10233	1				
35	Split Pin	PL10242	1				

L50 & L60 MODEL HAND PALLET TRUCK

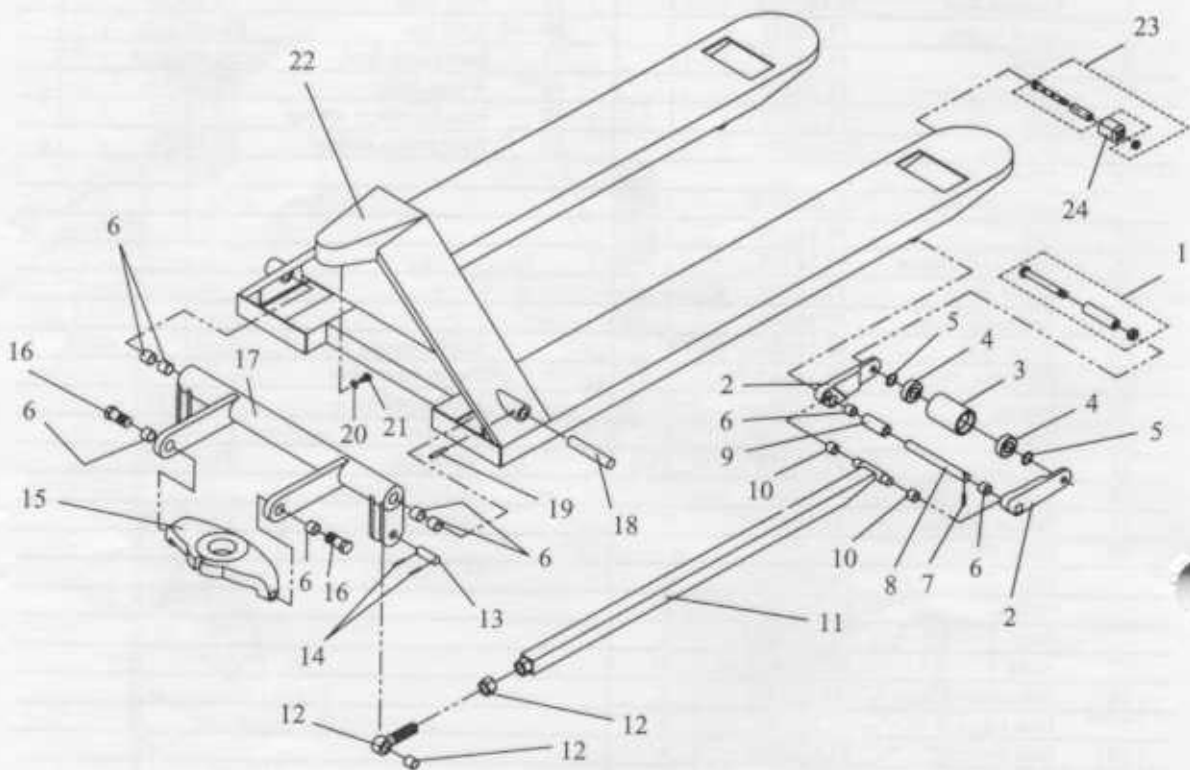

Item No.	DESCRIPTION	Part Number	Quantity
1	Axle includes bolt, sleeve, and nut	PL10215	2
2	Lever arm assembly includes bushings (items #6 and #10)	PL10212	2
3	Load roller		
	-Polyurethane	PL10210P	2
	-Nylon	PL10210N	2
	-Steel	PL10210S	2
4	Ball Bearing	PL10214	4
5	Spacer washer	PL10216	4
6	Bushing	PL10203	10
7	Split pin	PL10209	2
8	Fork pin	PL10219	2
9	Exit roller	PL10220	2
10	Bushing	PL10206	6
11	Push Bar		
	-36" Fork length (5000lb)	PL10224x36	2
	-42" Fork length (5000lb)	PL10224x42	2
	-48" Fork length (5000lb)	PL10224x48	2
	-36" Fork length (6000lb)	P610224x36	2
	-42" Fork length (6000lb)	P610224x42	2
	-48" Fork length (6000lb)	P610224x48	2
12	Eye bolt includes nut and bushings	PL10226N	2
13	Eye bolt pin	PL10227	2
14	Split pin	PL10228	4
15	Thrust plate	PL10231	1
16	Shoulder bolt	PL10275	2
17	Torsion bar		
	-20.5" wide truck	PL10201	1
	-27" wide truck	PL10202	1
18	Bulk head pin	PL10204	2
19	Split pin	PL10269	2
20	Lock Washer	PL10232A	1
21	Lock bolt	PL10232	1
22	Frame-(Specify length, width and capacity)	PL10200	1
23	Entry roller axle assembly	PL10285	2
24	Entry roller	PL10281	2

**L50M LOW PROFILE/ L50MU ULTRA LOW
PROFILE HAND PALLET TRUCK DIAGRAM**

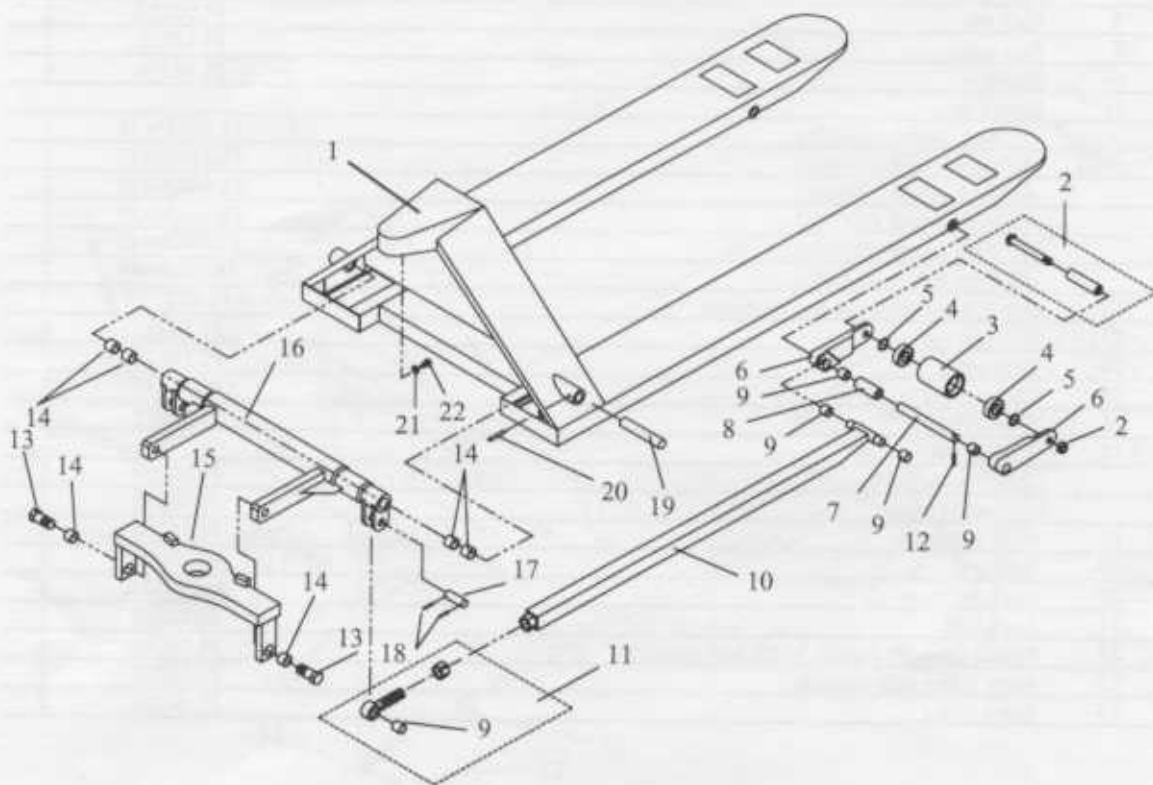

Item No.	DESCRIPTION	Part Number	Quantity
1	CHASSIS		
	-L50M (2" low profile)	PM10200	1
	-L50MU (1.75" ultralow profile)	PM10200U	1
2	Axle includes bolt, sleeve, and nut	PM10215	2
3	Load roller (L50M)		
	-Steel	PM10210	2
	-Polyurethane	PM10210P	2
	Load roller (L50MU)		
	-Steel	PM10210U	2
4	Bearing (L50M)		
	-Steel/Poly load roller	PM10214S	4
	Bearing (L50MU)		
	-Steel	PM10214P	4
5	Spacer washer	PL10216	4
6	Lever arm assembly includes bushings		
	-L50M	PM10212	2
	-L50MU	PM10212U	2
7	Fork pin	PM10219	2
8	Exit roller	PM10220	2
9	Bushing	PL10206	10
10	Push Bar		
	-L50M (specify forklength)	PM10224x	2
	-L50MU (specify forklength)	PM10224x4_U	2
11	Eye bolt includes nut, and bushing	PL10226N	2
12	Split pin	PL10269	4
13	Shoulder bolt	PL10275	2
14	Bushing	PL10203	2
15	Thrust plate	PF10231	1
16	Torsion bar		
	-20.5" wide truck	PM10201	1
	-27" wide truck	PM10202	1
17	Eye bolt pin	PL10227	2
18	Split pin	PL10228	4
19	Bulkhead pin	PM10204	2
20	Split pin	PL10269	2
21	Lock Washer	PL10232A	1
22	Lockbolt	PL10232	1

4-WAY HAND PALLET TRUCK DIAGRAM
L50M-4WAY/L50MU-4WAY

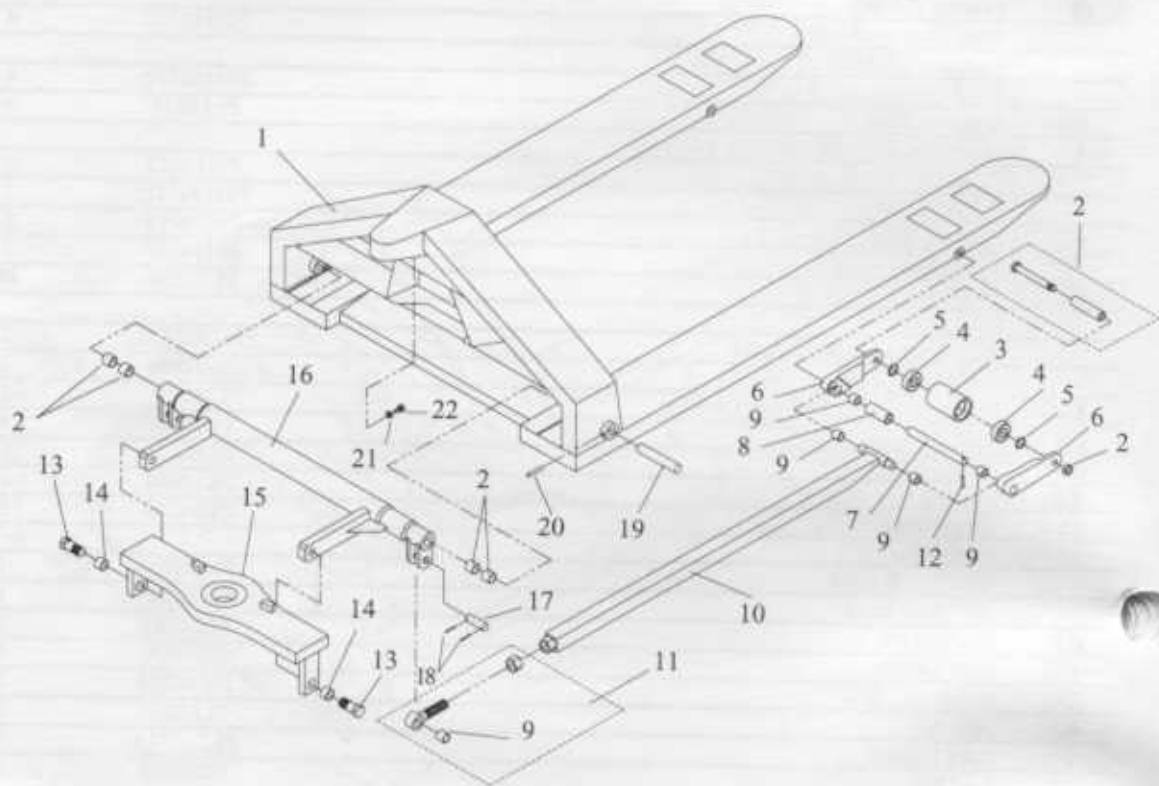

Item No.	DESCRIPTION	Part Number	Quantity
1	CHASSIS		
	-L50M-4WAY (2" low profile)	PF10200	1
	-L50MU-4WAY (1.75" ultralow profile)	PF10200U	1
2	Axle includes bolt, sleeve, and nut	PM10215	2
3	Load roller (L50M)		
	-Steel	PM10210S	2
	-Polyurethane	PM10210P	2
	Load roller (L50MU)		
	-Steel	PM10210U	2
4	Bearing (L50M)		
	-Steel/Poly load roller	PM10214S	4
	Bearing (L50MU)		
	-Steel	PM10214P	4
5	Spacer washer	PL10216	4
6	Lever arm assembly includes bushings		
	-L50M	PM10212	2
	-L50MU	PM10212U	2
7	Fork pin	PM10219	2
8	Exit roller	PM10220	2
9	Bushing	PL10206	10
10	Push Bar		
	-L50M-4WAY	PM10224x48	2
	-L50MU-4WAY	PM10224x48U	2
11	Eye bolt includes nut, and bushing	PL10226N	2
12	Split pin	PL10269	4
13	Shoulder bolt	PL10275	2
14	Bushing	PL10203	2
15	Thrust plate	PF10231	1
16	Torsion bar	PF10203	1
17	Eye bolt pin	PL10227	2
18	Split pin	PL10228	4
19	Bulkhead pin	PM10204	2
20	Split pin	PL10269	2
21	Lock Washer	PL10232A	1
22	Lockbolt	PL10232	1

HEAVY DUTY PUMP DIAGRAM

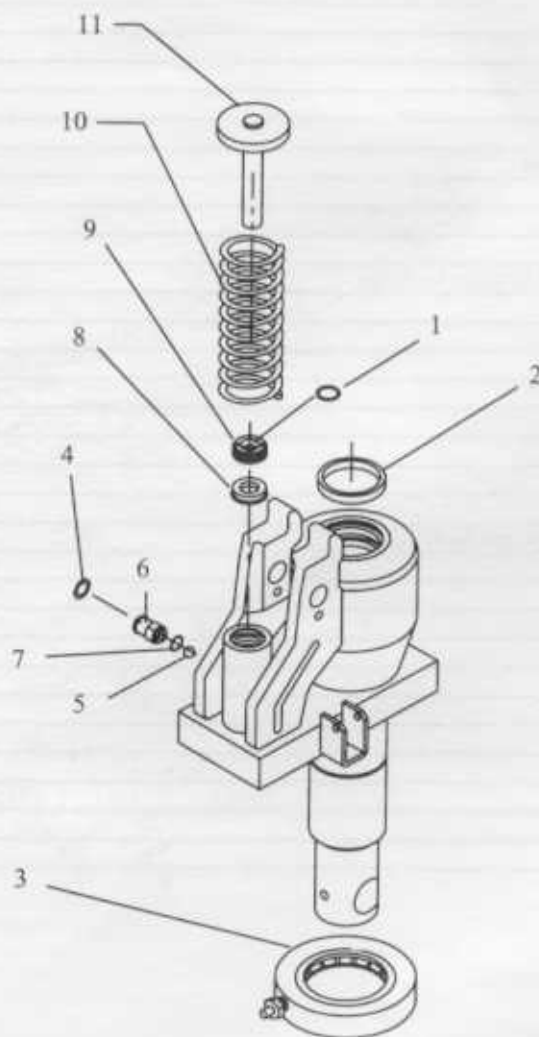

Item No.	DESCRIPTION	Part Number	Quantity
1	"O" Ring	PH10251	1
2	Seal	PH10246	1
3	Heavy Duty Bearing Assembly	PH10234	1
4	"O" Ring	PH10265	1
5	Ball	PL10254	1
6	Ball Valve	PH10262	1
7	"O" Ring	PH10256	1
8	Seal	PH10252	1
9	Piston Nut	PH10277K	1
10	Handle Return Spring	PL10253	1
11	Pump Piston	PH10250	1
Replacement kits available			
	Heavy duty seal kit	PH10278	1
	Heavy duty valve kit	PH10279	1
	Heavy duty complete repair kit	PH10280	1
	Pump Assembly (8000 & 10000 lb)	PH10277	1

Note:

Parts shown are unique to the heavy duty hand pallet truck pump. Parts not shown are the same as the standard pump.

LIFT-RITE[®]

**L80 (8,000 LB CAPACITY) & L100 (10,000 LB CAPACITY)
MODEL HAND PALLET TRUCK**

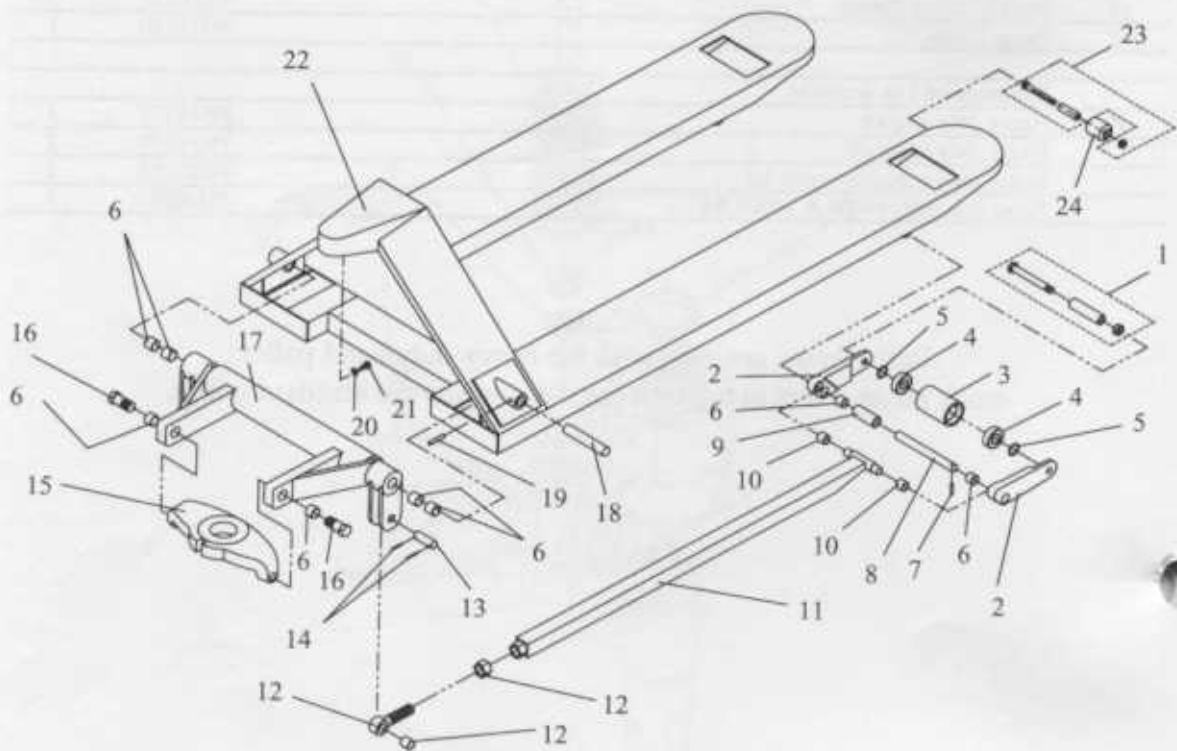

Item No.	DESCRIPTION	Part Number	Quantity
1	Axle includes bolt, sleeve, and nut		
	-8,000 lbs capacity	PL10215	2
	-10,000 lbs capacity	PH10215	2
2	Lever arm assembly includes bushing (items #6, and #10)		
	-8,000 lbs capacity	PL10212	2
	-10,000 lbs capacity	PH10212	2
3	Load Roller - Steel	PL-10210S	2
4	Ball Bearing	PL10214	4
5	Spacer Washer	PL10216	4
6	Bushing	PL10203	6
7	Split Pin	PL10209	2
8	Fork Pin	PL10219	2
9	Exit Roller	PL10220	2
10	Bushing	PL10206	2
11	Push Bar		
	-8,000 lbs capacity (Specify fork length)	PH10224x	2
	-10,000 lbs capacity (Specify fork length)	PX10224x	2
12	Eye bolt includes nut and bushing	PL10226N	2
13	Eye bolt pin	PL10227	2
14	Split pin	PL10228	4
15	Thrust Plate	PL10231	1
16	Shoulder bolt	PL10275	2
17	Torsion Bar		
	-8,000 lb capacity (20.5" wide truck)	PH10201	1
	-8,000 lb capacity (27" wide truck)	PH10202	1
	-10,000 lb capacity (20.5" wide truck)	PX10201	1
	-10,000 lb capacity (27" wide truck)	PX10202	1
18	Bulkhead pin	PL10204	2
19	Split pin	PL10269	2
20	Lockwasher	PL10232A	1
21	Lockbolt	PL10232	1
22	Frame- (Specify length, width and capacity)		
	-8,000 lb capacity	PH10200	1
	-10,000 lb capacity	PX10200	1
23	Entry roller axle assembly	PL10285	2
24	Entry roller	PL10281	2

OPTIONAL TANDEM LOAD ROLLER - PT30210

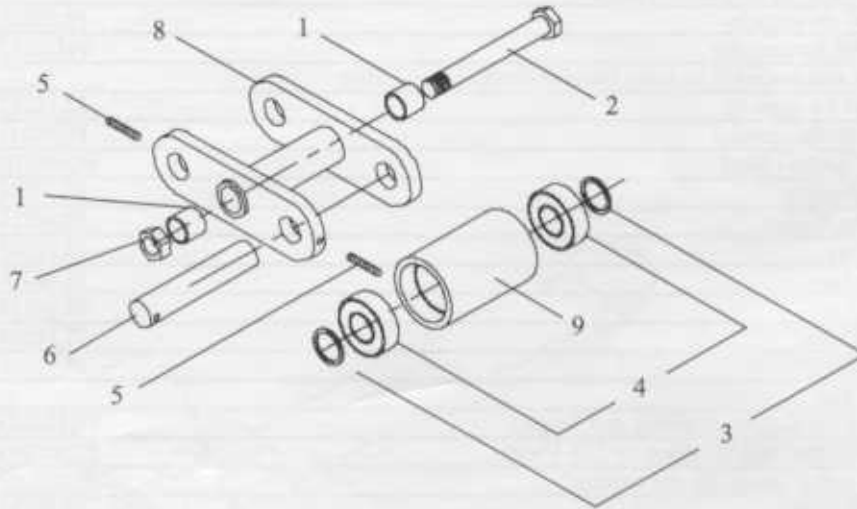

OPTIONAL BRAKE ASSEMBLY - PB40210

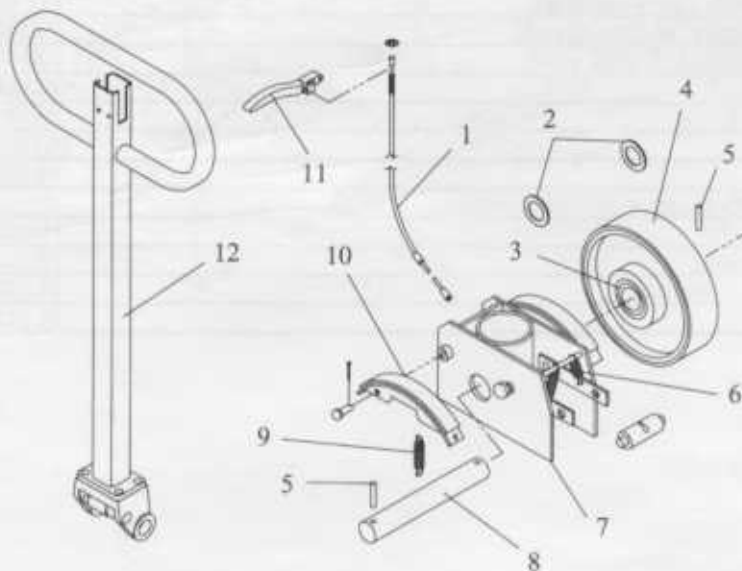

OPTIONAL TANDEM LOAD ROLLER - PT30210

Item No.	DESCRIPTION	Part Number	Quantity
1	Bushing	PT30216A	2
2	Axle	PL102151	1
3	Washer	PL10219A	4
4	Bearing	PM10214S	4
5	Set Screw	MI-SETDC.75	2
6	Pin	PT30212	2
7	Lock Nut	PL10218	1
8	Tandem Bracket	PT30211	1
9	Roller		
	-Nylon	PT30213N	2
	-Steel	PT30213S	2
	-Poly on Steel	PT30213P	2

OPTIONAL BRAKE ASSEMBLY - PB40210

Item No.	DESCRIPTION	Part Number	Quantity
1	Brake Cable c/w Nuts	PB40217	1
2	Washer	PL10239	4
3	Brake Bearing	PB40221	4
4	Brake Wheel	PB40220	2
5	Split Pin	PL10242	2
6	Internal Brake Spring	PB40216I	2
7	Brake Box Assembly	PB40211	1
8	Brake Axle	PB40222	1
9	External Brake Spring	PB40216E	2
10	Brake Shoe Set	PB40212	1
11	Brake Lever	PB40219	1
12	Outer Brake Handle	PB10274	1