



Owner's Manual, Operating Instructions Manual, and Replacement Parts Manual

**Lift-Rite Titan Series Hand Pallet Trucks
Model LCS80 - High Capacity**



Lift-Rite, 5975 Falbourne Street, Mississauga, Ontario L5R3L8 **Tel:** Toll Free from USA: 1-800-558-6012; **Tel:** 1-905-456-2603 (Canada and International)

Fax: 1-905-456-1383 Owner's Manual, Operating Instructions, and Replacement Parts Manual, Publication Number 1156118B ©2013

Dated 08 Oct 2013



This publication, 1156118B, applies to the Lift-Rite Titan Series Hand Pallet Trucks, Model LCS80 version, and to all subsequent releases of this product until otherwise indicated in new editions. Changes occur periodically to the information in this publication.

To order additional copies of this manual, part number 1156118B, contact your local authorized Lift-Rite Sales and Service Center.

If you need assistance with your lift truck, contact your local authorized Lift-Rite Sales and Service Center.

To locate your Sales and Service Center, go to www.liftright.com

©2013

Lift-Rite, 5975 Falbourne Street, Mississauga, Ontario L5R3L8 **Tel:** Toll Free from USA: 1-800-558-6012; **Tel:** 1-905-456-2603 (Canada and International)

Fax: 1-905-456-1383 Owner's Manual, Operating Instructions, and Replacement Parts Manual, Publication Number 1156118B ©2013

Dated 08 Oct 2013



TABLE OF CONTENTS

DELIVERY INSPECTION	2
OPERATING INSTRUCTIONS	2
SAFETY PROCEDURES	3
DAILY INSPECTION	3
MAINTENANCE	4-5
TROUBLESHOOTING	6
PARTS	7-9
Hydraulic Assembly	7
LCS80 Chassis	8
Recycling Old Parts	9
WARRANTY	10



SAFETY SHOES

Always wear safety shoes when working with hand pallet trucks.



PROTECTIVE GLASSES

When assembling or dismantling a hand pallet truck, protective glasses *must* be worn to avoid personal injury.

OPERATOR'S RESPONSIBILITY

While operating a hand pallet truck, *always* wear safety equipment and operate in a responsible manner to ensure a safe work area.

DELIVERY INSPECTION

Visually inspect hand pallet truck frame components and hydraulic unit for damage during shipment by carrier. If damage is evident, notify delivering carrier immediately and file necessary claims. Test the hand pallet truck pump for proper operation. **If the hydraulic pump does not respond to movement of the handle, an air lock may have developed during shipping. To remedy this, go to the user friendly TROUBLESHOOTING guide in this manual.**

OPERATING INSTRUCTIONS

(Read and understand prior to using this product)

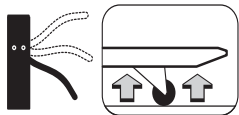

→ To raise the load, push down on the fingertip control. Pump the handle to raise the load from the floor.

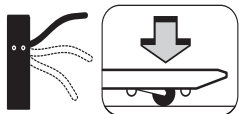

→ To lower the load, pull up on the fingertip control.

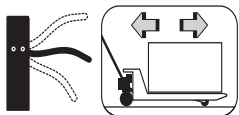

→ For free handle movement, place the fingertip control in the neutral position.

NOTE:

The neutral position disengages the pump from the lifting mechanism. This frees the handle, which makes pulling loads easier. In addition, the pump is not subject to shock pressures while the truck is in motion.



SAFETY PROCEDURES

(Read and understand prior to using this product)

- Read and obey all labels on this product. If you have any questions about these, ask your supervisor.
- Do *not* operate this hand pallet truck unless you are authorized and trained to do so.
- *Never* overload your hand pallet truck. Stay within its rated capacity.
- Do *not* operate this truck if damaged or not in proper working order.
- Distribute the load evenly on the forks. Do *not* concentrate loads at one point or load one fork more than the other.
- When the load impairs visibility, the hand pallet lift truck should be pulled and not pushed.
- *Always* look where you are operating. Keep a clear view.
- Only handle loads on flat level surfaces. Do *not* use a loaded truck on inclines or declines.
- *Never* carry passengers.
- *Never* put your feet, hands, or any other body part under the frame assembly.
- *Always* yield right of way to pedestrians.
- Do *not* allow your hand pallet truck to drop from one level to another. Even a drop of 1 in. (25 mm) more than doubles the effective load momentarily and results in a loading that can bend or break components.
- Move loads only with the hand pallet truck in its lowest position.
- *Always* make sure that the load is stable before moving to eliminate the opportunity for load shift.
- Use extreme care when rounding corners. Too fast a speed could cause a hand pallet lift truck to tip. If loaded, the load could shift and fall.
- When not in use, fully lower the forks.

DAILY INSPECTION

At the start of your shift, check the items listed below. Report any malfunction or unsafe conditions to your supervisor. Do not use this product until it is repaired.

CHECK POINTS	Steering	Hydraulic System	Wheels	Chassis/ Handle	Lifting/ Lowering	Labels
ACTION	Check full rotation	Check for excessive oil on exterior and check for function	Check for wear, damage, and remove debris	Check for damage and remove debris	Check for function	Check for readability



MAINTENANCE

LUBRICATION

All pivot points are equipped with permanently lubricated bushings and bearings. To increase bearing life, it is recommended that a few drops of light machine oil be applied at each pivot point every 6 months. The thrust plate is equipped with three grease fittings. Apply grease under normal conditions every 6 months.

PUSH BAR LINKAGE ADJUSTMENT

If the forks do *not* rise evenly at the tips, or the roller levers begin to drag on the floor, the following adjustment is necessary:

LCS80 MODEL

- Turn the hand pallet truck over so that the underside of the forks are accessible.
- Remove one split pin (PL-20269) with 3/16 in. punch.
- Remove pin (PL-20227) from bracket.
- Adjust eyebolts (PH-20226). Turn counterclockwise to raise fork tips and clockwise to lower fork tips.
- Replace pin (PL-20227) through eyebolt and replace split pin (PL-20269).
- When adjusted properly, the forks should be 3-1/4 in. low height from ground level in the lowered position.



MAINTENANCE (CONT.)

HYDRAULIC SYSTEM

Your hydraulic system is maintenance free. Do *not* add hydraulic oil unless there is, or has been, a leak. Use Premium HVI hydraulic oil or equal. Other oils, fluids, or solvents may damage your hydraulic system. If you suspect additional oil is required, follow these steps:

1. Check for and fix any possible oil leaks.
2. Lower the truck and load with 600 lbs. (approximate).
3. Pump the truck to its maximum lift height.
4. Measure the vertical height of the exposed piston (7535745) and refer to the chart below.

Distance (inches)	5-1/8 in.	4-3/4 in.	4-3/8 in.	4 in.	3-1/2 in.	3-1/8 in.	2-3/4 in.	2-3/8 in.
Oil to add (Fl. Oz.)	0	2.7	3.0	3.4	3.7	4.0	4.4	4.7

ADDING OIL (IF REQUIRED)

1. Place and secure the truck on its right side (release valve facing the floor).
2. Pull up on the release lever (PL-40274BDM) and extend the lift piston fully.
3. Remove screw (221586A) and add the amount of oil determined by the chart in step 4.
4. Reinstall screw (221586A) but do not tighten. Leave a 1/32 in. gap.
5. Pull up on the release lever (PL-40274BDM) and collapse the lift piston until oil starts to ooze from the screw.



CAUTION! - It is extremely important that step 5 is performed. Otherwise, air in the pump can force out the wiper seal (20066). Take care when adding oil not to introduce impurities into the hydraulic system.

6. Tighten the screw (221586A) fully and return the truck upright.



TROUBLESHOOTING

CONDITION	POSSIBLE CAUSE	ACTION
Pump does not lift load.	An air lock in the hydraulic system.	Pull up on fingertip control and hold while pumping the handle 8 to 10 times to bleed air from the system.
Lifting, neutral, and lowering do not function properly.	Chain anchor out of adjustment.	Turn nut (21094) on chain anchor clockwise until pumping action, while in neutral, does not raise forks.
Forks raise and sink with pump action.	Dirt or foreign particle caught in cone valve seat.	Pull up on fingertip control and hold while pumping the handle 8 to 10 times to purge the valve system.
Pump does not lift load to complete raised height.	Pump is low on oil.	Check for and fix any leaks. Then add oil as instructed in the MAINTENANCE section.
Forks are not lowering completely.	Push jam nut is loose. Push bars require adjustment.	Refer to Push Bar Linkage Adjustment in the MAINTENANCE section.



COMPLETE HYDRAULIC ASSEMBLY (1153106/001)

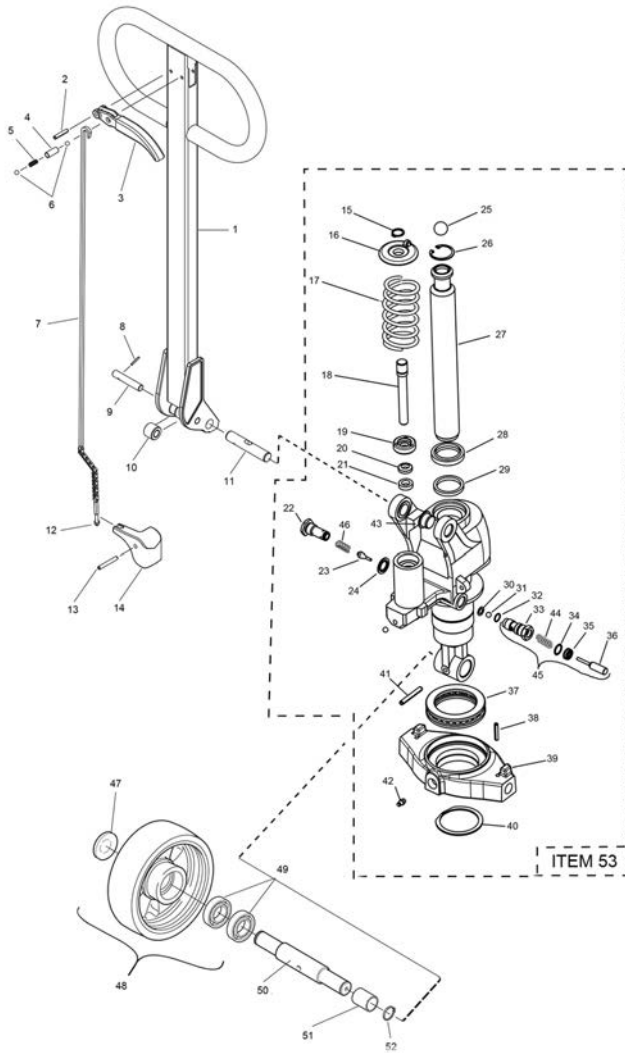

ITEM	DESCRIPTION	QTY	PART NO.
1	COMPLETE HANDLE (ITEMS 2-10)	1	PL-40276M
2	SPLIT PIN	1	20105
3	CONTROL LEVER	1	PL-40274BDM
4	CONTROL LEVER SLEEVE	1	54140
5	CONTROL LEVER SPRING	1	218182
6	CHROME BALL	2	20065
7	CONTROL ROD ASSEMBLY	1	215775
8	SPLIT PIN	1	20461
9	AXLE	1	47930
10	ROLLER W/BUSHING	1	202755
11	AXLE	1	7500086
12	ADJUSTING NUT	1	21094
13	LOCKING PIN	1	220312
14	LOWERING ARM	1	7500110
15	LOCKING RING	1	20004
16	WASHER	1	226743A
17	SPRING	1	315156
18	PISTON	1	7500079
19	SEAL HOLDER	1	7500089
20	SEALING	1	7500130
21	SEALING	1	7500131A
22	SCREW	1	221586A
23	VALVE CONE	1	2223935
24	WASHER	1	235545
25	BALL	1	PL-10244
26	LOCKING RING	1	PL-20232
27	PISTON	1	7535745
28	SEALING	1	20066
29	SEALING	1	245867
30	WASHER	1	215288A
31	BALL	1	20065A
32	O-RING	1	22032
33	VALVE BODY	1	7500112
34	SEAL	1	22032
35	U-RING	1	7500100A
36	PISTON	1	7523958
37	BALL BEARING	1	213056
38	LOCKING PIN	1	20001
39	THRUST PLATE	1	215092
40	LOCKING RING	1	21737
41	LOCKING PIN	1	220312
42	GREASE FITTING	1	27662
43	BUSHING	1	215913
44	SPRING	1	47071
45	LOWERING VALVE COMPLETE	1	7500107
46	SPRING	2	39106
47	COVER	1	156623BT
48	WHEEL COMPLETE - STEEL	1	160433
49	BEARING	1	22226
50	AXLE	2	220310
52	LOCKING RING	2	20019
53	HYDRAULIC UNIT	1	7500129
54	REBUILD KIT	4	Consult Lift-Rite



MODEL LCS80 CHASSIS DIAGRAM

ITEM	DESCRIPTION	QTY	PART NO.
1	CHASSIS COMPLETE (27 X 48)	1	1154479/002
2	TORSION BAR	1	1154048/001
3	BUSHING	6	PL-20206
4	THRUST PLATE PIN	2	166701
5	EYE BOLT PIN	2	PL-20227
6	SPLIT PIN	6	PL-20269
7	BUSHING	2	PL-20203A
8	BUSHING	2	PL-20226A
9	EYE BOLT WITH BUSHING AND NUT	2	PH-20226
10	EYE BOLT NUT	2	PL-10224AF
11	PUSH BAR		
	48 IN. LONG FORK	2	PH-20224X48
12	LEFT LEVER ARM WITH BUSHINGS	2	PL-20212-L
13	RIGHT LEVER ARM WITH BUSHINGS	2	PL-20212-R
14	BUSHING	2	PL-20203
15	LOCK NUT	2	PL-10218
16	FORK PIN	2	PH-20219
17	BUSHING	4	PL-10203
18	EXIT ROLLER	2	PL-20220
19	AXLE - LOAD ROLLER	2	PL-20215-I
20	LOAD ROLLER	2	PL-20210S-BRG
21	BEARING	4	PL-20214
22	BULKHEAD PIN	2	PL-20204

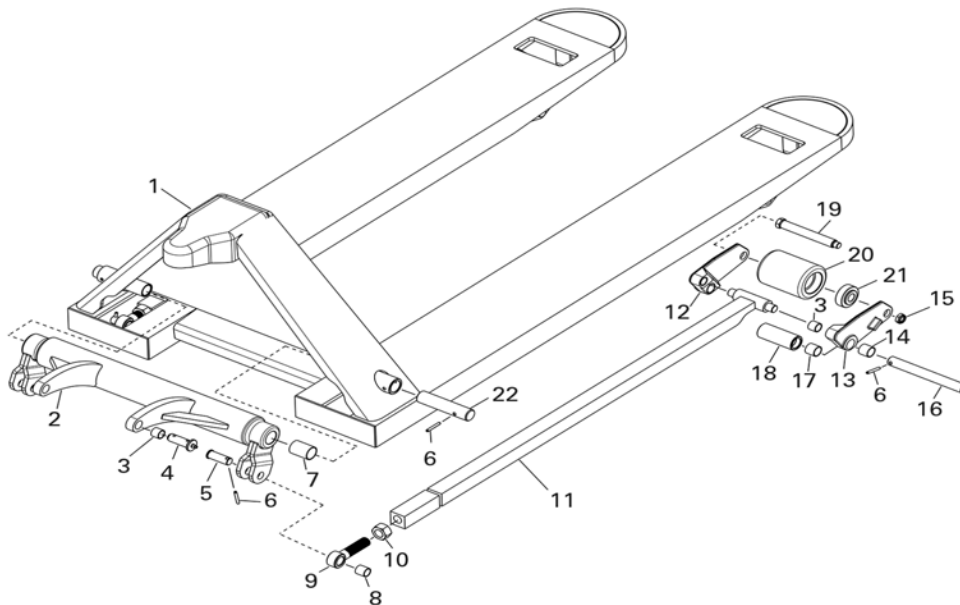



RECYCLING YOUR OLD LIFT-RITE PARTS



Chassis	Steel
Roller suspension	Steel and cast iron
Bushings	Brass
Grease fittings	Steel
Rollers	Steel
Hydraulic body	Cast iron
Thrust plate	Cast iron
Handle	Steel
Wheel	Steel
Bushings	Brass
Hydraulic oil	Disposal in accordance with local regulations
Assembly parts	Steel, brass, nylon



HAND PALLET TRUCK WARRANTY

The Lift-Rite Titan Series Hand Pallet Trucks, Model LCS80 version, are warranted against defects in materials and workmanship for a period of six (6) months from date of installation.

Components found to be defective by an authorized Lift-Rite Sales and Service Center during the warranty period will be replaced or repaired as indicated above. Replacement components installed during the defined period set forth above, are warranted for the balance of the applicable truck warranty period, or 90 days, whichever is longer. Additionally, freight charges for parts involved in the replacement or repair of a defective component will be paid by Lift-Rite, provided that the replacement or repair is made by an authorized Lift-Rite Sales and Service Center. Labor or miscellaneous costs involved in the replacement of any components determined to be defective are not covered. Local taxes, if any, are excluded.

This warranty is void in the event of defects or damage caused by misuse, abuse, or accident. Any truck used under adverse conditions, such as fish, meat, or poultry processing plants, tanneries, freezer applications, or any other application where the unit is operating in water or subjected to fluid or chemicals is NOT covered under any warranty.

This warranty does not cover oil leaks, adjustments, or loose hardware.

Lift-Rite reserves the right to make changes and improvements in design without making changes to previously manufactured vehicles.

Notwithstanding any other language contained herein, this warranty is expressly voided without any further notice if any modification is made to the Lift-Rite equipment, or if additional components or devices are added to the Lift-Rite equipment, without prior approval having been granted in writing by Lift-Rite.

THIS WARRANTY IS IN LIEU OF ALL OTHER WARRANTIES, EXPRESSED, IMPLIED, OR STATUTORY. THERE ARE NO WARRANTIES OF MERCHANTABILITY OR FITNESS FOR A PARTICULAR PURPOSE. In no event shall Lift-Rite be liable for incidental, special, or consequential damages.

LIFTRITE®

Lift-Rite, 5975 Falbourne Street, Mississauga, Ontario L5R3L8 **Tel:** Toll Free from USA: 1-800-558-6012; **Tel:** 1-905-456-2603 (Canada and International)

Fax: 1-905-456-1383 Owner's Manual, Operating Instructions, and Replacement Parts Manual, Publication Number 1156118B ©2013

Dated 08 Oct 2013