

LIAFRITE

LEC 2300
PST 5000

Operator's Manual/Service

Page

1 - 12

Serial number: 3 980 000

Issued: 2015-05-04



The product complies with
the CE-directives

PALLET TRUCKS

Operator's Manual/Service

en

Translation of the original instruction



WARNING!

Do not use the truck before first reading through the OPERATOR'S MANUAL.

NOTE!

Keep for future reference.

STD = Standard

U = 75 mm fork height

O = Overload

Q = Quick Lifter

X = Hand brake

P/PST 5000 = Start assistance

With reservation for deviations in the product range.



DANGER!

DANGER!

Warns that an accident **will** occur if you do not follow the instructions.

The consequences are serious personal injury or possibly death and/or extremely large material damage.



WARNING!

WARNING!

Warns that an accident **can** occur if you do not follow the instructions.

The consequences are serious personal injury or possibly death and/or extremely large material damage.



CAUTION!

CAUTION!

Warns that an accident **can** occur if the instructions are not followed.

The consequences are personal injury and/or material damage.

NOTE!

NOTE!

Marks the risk of damage of the truck if the instructions are not followed.

It is the responsibility of the employer to ensure that all users of the truck possess sufficient knowledge in safe use of the truck.

Safety regulations



SAFETY SHOES

Always wear safety shoes when working with the truck.



PROTECTIVE GLASSES

Always wear protective glasses when assembling or dismantling the truck to avoid personal injury.

Control

The truck must not be used if it is damaged or has any faults that affect safety or its safe use. Also do not use the truck if it has been repaired or adjusted unless it has been checked and approved by an authorised service technician.

Operating the truck

The truck may be used only on a firm and even surface, such as concrete or asphalt.

It is not permitted to use the truck:

- In areas where the atmosphere contains gases that can cause fire or explosion. In such environments, a special explosion-proof truck is required.
- To transport/lift passengers.
- In cold stores or salty and other corrosive environments. Use a **stainless steel** truck in this type of environment.

Operator's responsibility

- The truck shall only be driven with care, good judgement and in a responsible manner.
- The truck should **not** be driven with oily hands or oily shoes due to the risk of slipping.
- Never wear loose objects or jewellery when working on the truck.

Working area

- Ensure that the floor where the truck is to be used has sufficient load bearing capacity for the total weight of the truck including the maximum load.
- Take special care if there are protruding parts from racks, shelves or walls that can cause injury or damage the truck.
- It is **prohibited** for persons to be present in the area around the truck when there is a risk of personal injury, e.g. areas that can be reached by falling goods, lowering load handling devices or in the truck's manoeuvring area.

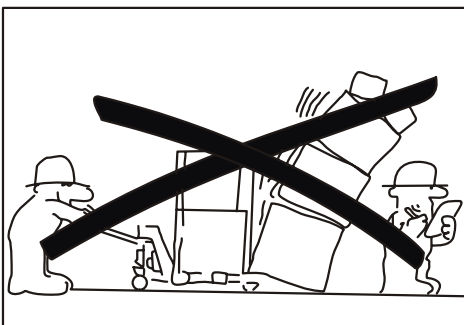

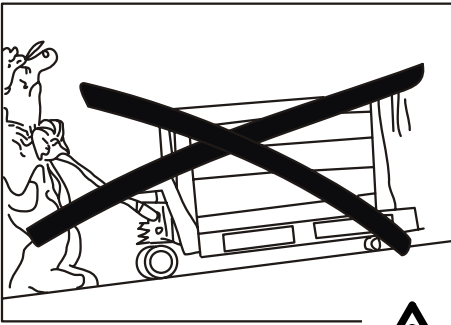

Operating and conduct while operating

- Avoid cornering at high speed.
- Pay particular attention to other personnel as well as fixed and moving objects within the working area and thereby avoid accidents.
- Always pull the truck behind you if the load blocks the view.



CAUTION!

*When operating on inclines, the truck must be operated with extreme care with the load facing downwards in the direction of the incline.
Use trucks with a hand brake.*



WARNING!

Braking shall take place gently and carefully to prevent the load from slipping off of the forks and causing damage.



CAUTION!

Adapt the speed according to the incline and surface.

- Always keep a safe distance from the edges of loading docks and loading ramps. Be attentive to marked risk areas.

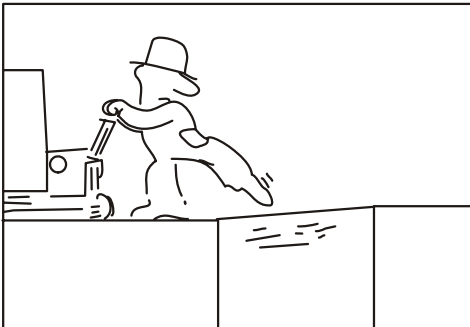

- Before the truck is driven on to a loading ramp ensure that the ramp is correctly secured and has the necessary load bearing capacity. Drive slowly and carefully across the ramp.

- When the truck is driven on to another vehicle, make sure the vehicle is stable and that the brakes have been applied correctly.

- Before the truck is driven into a lift, the operator must make sure the lift is approved for the total weight of the truck, the load, operator, and any other passengers in the lift. When entering the lift, the load must enter first, not the driver. No other personnel should be in the lift when the load or truck enters or leaves the lift.

- Any accidents that have caused personal injury or damage to buildings or equipment must be reported to the supervisor. Incidents and faults on the truck shall also be reported.

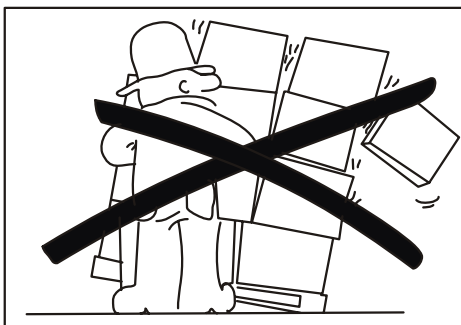

Handling loads

- Only handle loads that are within the truck's permitted lifting capacity. The length/width of the forks should be adapted to the load's shape and dimensions.
- Only loads that are stable, evenly distributed on the forks and safely arranged should be handled.



WARNING!

Risk of overturning.

Cornering: The load can fall from the truck if the speed is too high and cause damage. Cornering with a high load must be performed with extreme care.

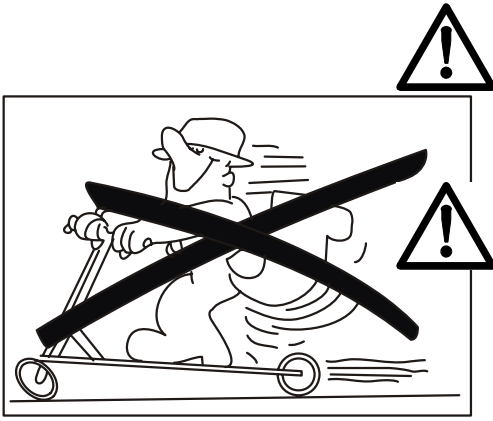

WARNING!

The truck may only be used to carry goods. It is prohibited to use the truck to transport persons, and as result it must not be used as a "scooter".

WARNING!

Risk of crushing under forks.

The risk of crushing can occur when lowering or by a defect in the hydraulic system and accidental lowering.

Be attentive to the risks of crushing and ensure that other persons are not in the immediate vicinity of the truck.

CAUTION!

Risk of crushing.

If the hands are placed on the outside of the handle, there is a risk of crushing in narrow spaces. There is also a risk of crushing if the hands are kept between the tow bar and the tow bar bracket, or between the top cap and the hydraulic unit.

Because of this, be sure to keep the hands only on the top of the handle when operating the truck.

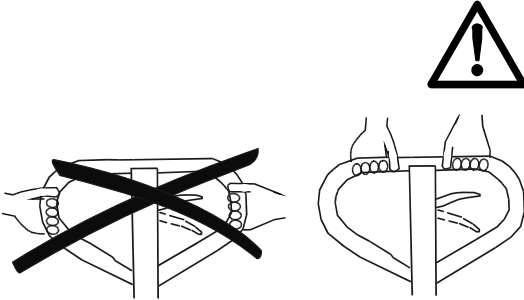

Parking the truck

When parking the truck, the forks must be fully lowered.

- **Never** park the truck on an incline.
- **Never** park the truck so that it obstructs traffic or work.

Maintenance and repair

- To prevent malfunction and accidents, the truck should be maintained regularly according to the *Lubrication diagram*. Only qualified and trained personnel are permitted to maintain, adjust or repair the truck.
- Only use Lift-Rite recommended spare parts for service and repairs. See the Lift-Rite spare parts catalogue.

Modifications or conversions to the truck that affect the safe use or function are not permitted.

It is recommended that you sign a service and maintenance agreement with your closest representative to ensure the truck's operating economy and safety.

Warranty

With every factory-delivered truck, a product warranty is included according to a separate specification. The warranty is valid under the assumption that maintenance and service is performed according to the recommendations from Lift-Rite, and is performed by Lift-Rite authorized personnel, and by using spare parts recommended by Lift-Rite.

Daily service/safety checks

Check points	Action
Steering	Function
Hydraulic system	Oil level/Oil leakage
Wheels	Damage, remove oil, metal chips and the like
Chassis	Damage, remove dirt etc.
Lifting/lowering	Function lift/neutral/lower positions
Signs	Readability

NOTE!

Never neglect daily inspection and the safety checks.

Serious injury can occur if neglected.

Any faults or damage that is detected, should be reported immediately to the supervisor. Never use a faulty truck.

Safety regulations with maintenance work

- Keep the area where you carry out the service clean. Oil or water makes the floor slippery.

NOTE!

Extreme cleanliness should be observed at all times when working with the hydraulics. Dismantled parts should be clean and inspected carefully. Always replace gaskets after dismantling.

- Store and dispose of changed oil in accordance with local directives.
- Do not release solvents and the like, which are used for cleaning/washing, into drains that are not intended for this purpose. Follow the local directives that apply for disposal.
- Remove at least 100 mm (4") of paint around the welding/grinding area through sand-blasting or the use of a paint stripper when welding or grinding on painted surfaces.



CAUTION!

Harmful gases.

Paint that is heated gives off harmful gases.

Remove 100 mm (4") of paint from the work area.



WARNING!

Risk of crushing.

A poorly supported truck may fall down.

To prevent the truck from overturning, make sure it has been properly secured.



WARNING!

Risk of crushing.

There is a risk of crushing when working on the hydraulic system if the truck is loaded.

Always unload the forks prior to work on the truck.

Cleaning and washing

Cleaning and washing of the truck is important to ensure the truck's reliability.

- Always lubricate the truck after washing according to the lubrication diagram and table.

Lubrication diagram

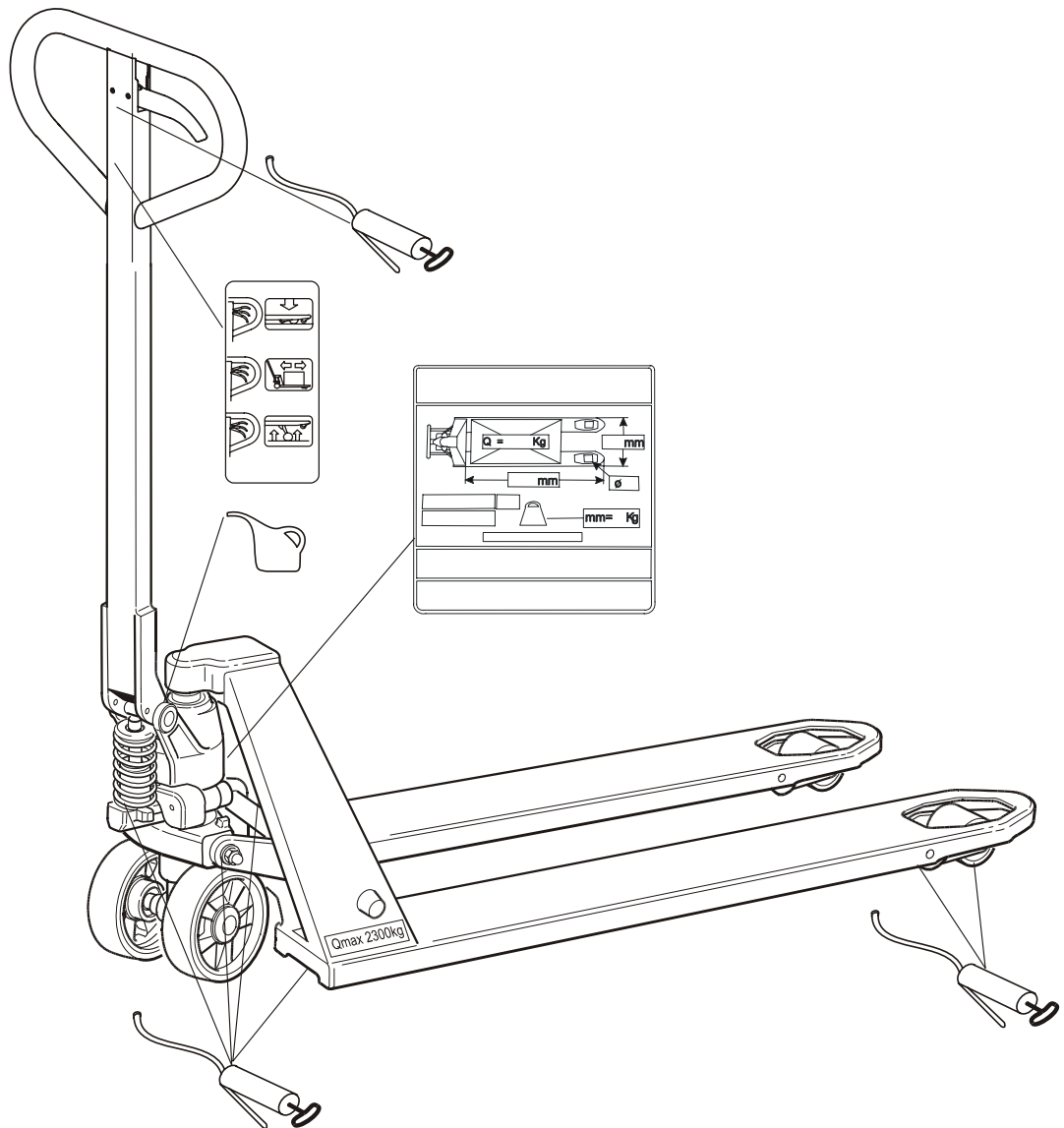

Oil and grease specification			
Lubricant	Specification	Product name	Order No.
Grease		OKQ8 Rubens WB	213366
Hydraulic oil >-15° C	ISO-VG32 Quality level: ISO 6743-4 category HM DIN 51524 part 2 category HLP	Hydraulic oil 32	1 litre: 233328-001 5 litres: 233328-002
Hydraulic oil <-15° C	ISO-VG27,5 Quality level: ISO 6743-4 category HV DIN 51524 part 3 category HVLP	Statoil 131	1 litre: 233916-001 5 litres: 233916-002

Information signs

The weight of the load must be within the truck's permitted lifting capacity, see the truck's identification plate.

NOTE!

If a plate is unreadable a new plate must be ordered.

Technical data

This table provides information on some technical specifications for the standard truck version. Please note that deviations from this information are possible.

Truck type	LEC2300/Q/X PST 5000	LEC2300P
Rated lifting capacity, kg ¹⁾	2300	2300
Lift height, mm	200	200
Height with raised tow bar, mm	1220	1220
Total length, mm	1500	1575
Weight, kg ¹⁾	63	75
Turning radius, mm	1370	1370
Wheel pressure	Please contact your local Lift-Rite representative for current information	

¹⁾ Correct value is specified on the truck's identification plate.

Lifting the truck



WARNING!

Risk of cutting.

There is a risk of cutting when the truck is lifted by hand and holding it by the forks and the end plate.

Always use work gloves when lifting by hand.



WARNING!

Risk of crushing.

There is a risk of crushing when the truck is lifted by hand and holding it by the hydraulics body.

Always use work gloves when lifting by hand.

Assembly instructions



NOTE:

Always wear PROTECTIVE GLASSES when assembling the truck.

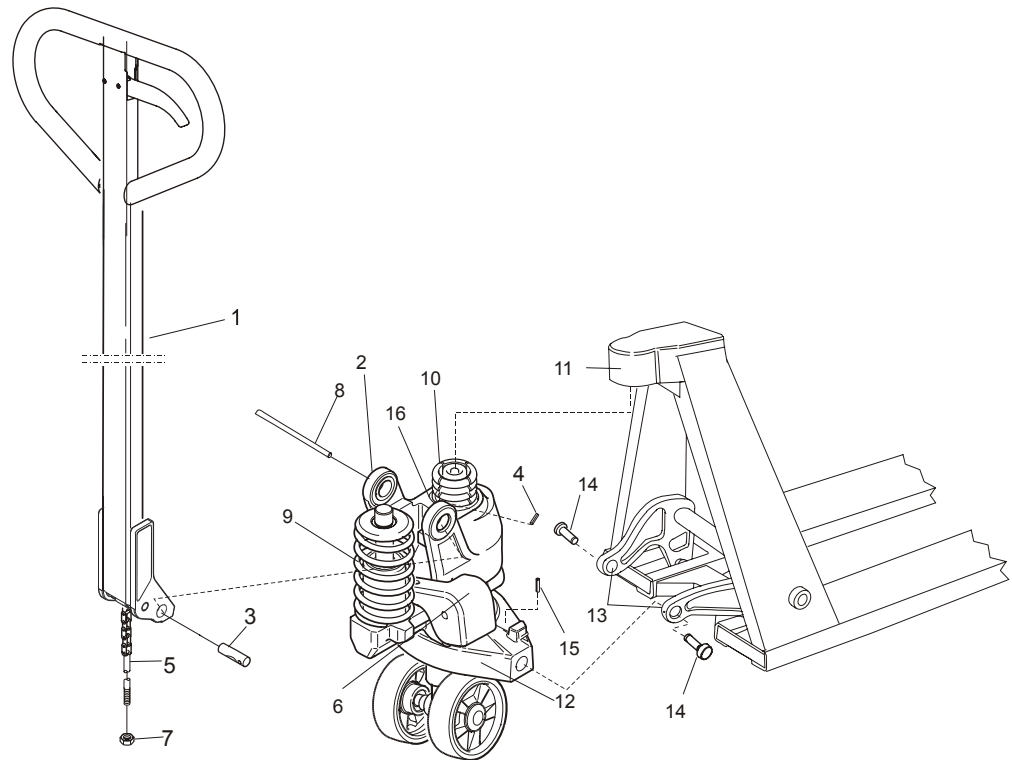

1. Assembling the tow bar:

Secure the tow bar (1) in the tow bar bracket (2). Fit the axle (3) in the bracket (2). Make sure the **tapered** hole of the axle (3) faces **downwards**. Lock the axle (3) using the locking pin (4). Slip the valve rod (5) through the hole onto the shaft (3). Engage the valve rod (5) in the groove of the lowering pedal (6). Adjust the lifting/lowering function and neutral position using the nut (7). Push down the tow bar and remove the transport pin (8) that has been fitted prior to delivery.



WARNING!

Released energy.

The spring (9) may come loose and cause injuries if the transport pin (8) is removed prior to assembling the tow bar (1). Always assemble the tow bar (1) before removing the transport pin (8).

2. Assembling the hydraulic unit in the frame:

Place the upper part of the hydraulic assembly (10) in the top cap (11). Insert the hydraulic assembly pressure plate (12) between the turning tube links (13). Fit the arm bolts (14) and lock them with locking pins (15). Lubricate the arm bolts (14). Install the circlip (16) in the groove of the top cap (11).



WARNING!

Released energy.

When fitting the circlip (16), there is a risk that the circlip can slip off the circlip bar and cause injury. Be careful when fitting the circlip.

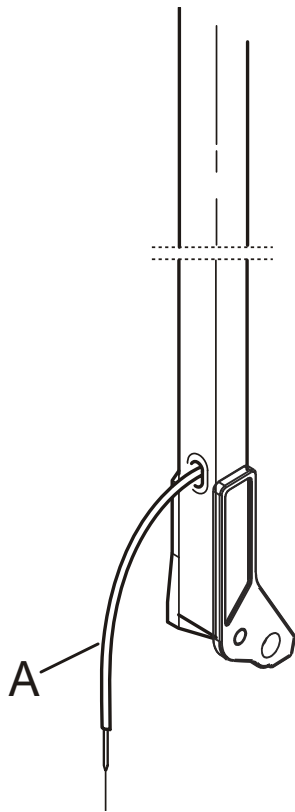

WARNING!

Released energy.

When inserting the locking pins (4, 15) using a hammer, it can bounce and cause injury.

Be careful when fitting the locking pins.

Operator instructions for the LEC 2300 X

In addition to all the other information in the operating instructions, the instructions below specifically apply to the LEC 2300 X.

- Before using the truck, make sure that the brake wire (A) is free from damage.
- Check that the braking effect is sufficient and adjust the cable tension if necessary.
- Pull the handbrake lever upwards to actuate the handbrake.

The handbrake is also equipped with a parking brake function. Press the locking catch towards the locking mechanism when the brake has been applied on the truck to lock the brake.



WARNING!

Never leave the truck in the raised position with the brake applied.

- Pull the brake handle upwards and move the lock catch outwards to release the parking brake.



CAUTION!

Risk of pinching. Never put your finger under the locking catch.



CAUTION!

Adapt the speed to the slope and surface.

Max. inclination is 5% for use of trucks fitted with a hand brake.



WARNING!

Risk of toppling.

A truck carrying a load can topple over when turning on inclines.

Never turn a loaded truck when driving on an incline.

Operator instructions for the LEC 2300 P/PST 5000

In addition to all the other information in the operating instructions, the instructions below specifically apply to the LEC 2300 P/PST 5000.

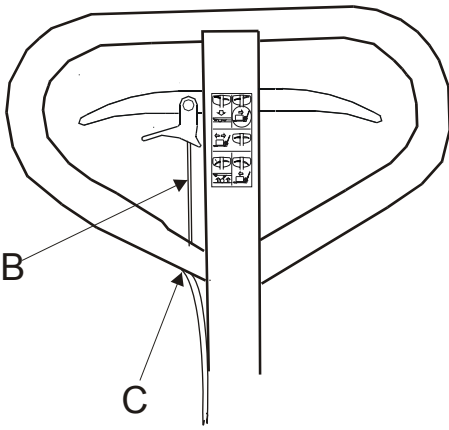

- Do **not** use the LEC 2300 P/PST 5000 in wet environments or in places with extreme temperature variations.
- Before using the truck, make sure that the start assist wire (B) is free from damage.
- When required, inspect the condition of the start assist wire and adjust wire tension (C).
- Prior to using the start assistance feature, set the hydraulic lowering handle (1) to the neutral position.
- Move the start assistance lever up or down (2) depending on the travel direction. When moving the lever down, be sure to first release the catch (3).
- When not using this feature, set the start assistance lever to the neutral position (4).

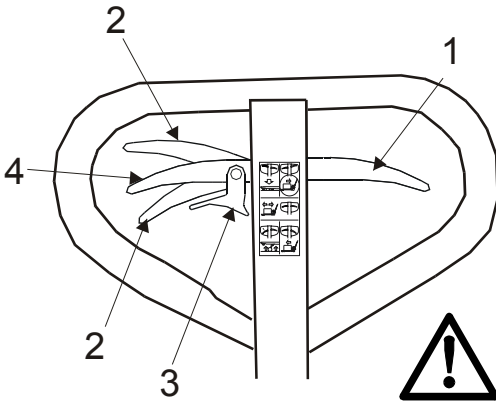

WARNING!

Energy released in the tow bar.

Incorrect use may result in injuries and damage to the truck.

Never use the start assistance feature to brake the truck. When the truck is moving, never set the start assistance lever to the opposite position of the travel direction.



CAUTION!

Risk of pinching. Never put your finger under the locking catch.

Additionally, never hold the hands around the start assistance link arm.



- Clean and lubricate the start assistance assembly inside in case of malfunction (blocking/seizure of wheels and/or handle).

Troubleshooting

LEC 2300 Fault	Cause	Action
Pump does not take a full stroke	Air in the hydraulic system. Insufficient hydraulic oil.	Pump 5 strokes with lowering valve open. Contact a service technician.
Lift, neutral and lowering positions do not function correctly	The lowering valve is incorrectly set	Adjust the setting of the valve chain using adjuster nut
The forks drop after every stroke	Leakage from the valve cone	Replace the valve cone and washer
LEC 2300 Q Fault	Cause	Action
Quick lift does not work	Ball valve leakage	Replace the quick rod
LEC 2300 P/PST 5000 Fault	Cause	Action
Lifting or the start assistance feature does not work satisfactorily	Lifting and start assistance have both been selected	Reset the function, which is not needed, to the neutral position
Start assistance does not engage when required	The wire has too much tension	Adjust wire tensioning using the adjustment screw
The start assistance wire is broken	Overloading	Return the clamp loop (1) to the neutral position for emergency travel and replace the wire

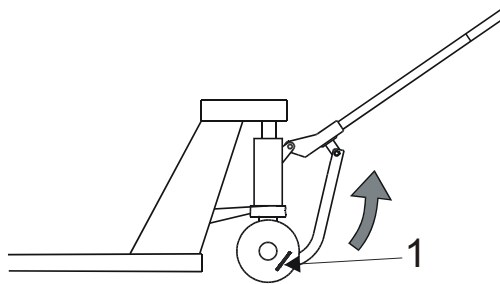

Recycling



Body:	Steel
Wheel suspension:	Steel and cast iron
Bushing:	Brass
Grease nipples:	Steel
Wheel:	Nylon, polyurethane, steel
Enamel:	Epoxy-polyester
Hydraulic body:	Cast iron
Pressure plate:	Cast iron
Tow bar:	Steel, nylon
Wheel:	Nylon, polyurethane, steel, rubber
Enamel:	Epoxy-polyester
Bushings:	Brass
Hydraulic oil:	Disposal acc. to local directives
Assembly parts:	Steel, brass, nylon

EC Declaration of Conformity

We,

Declare that the machine

Make:

Type:

Serial no:

Truck designation: Industrial truck

* Includes all variants

As described in attached documentation is in conformity with:

- The Machinery Directive 2006/42/EC by complying to following harmonised standards;
EN ISO 3691-5:2014 and EN 16307-5:2013

Name:

First name:

Position:

Place, date of issue)

Signature

The Product Development Department on the address above is authorised to compile the Technical file for the products for which this certificate is valid. For deliveries to countries outside the European Union, differences may occur with regard to requirements for documentation in the local language.

EC Declaration of Conformity

We
BT Products AB
SE-595 81 MJÖLBY
Sweden

Declare that the machine

Make: Lift-Rite
Type: LEC 2000*, LEC 2300*
Serial no(s): 3.980.000 – 4.099.999

Designation of machinery: Industrial Truck

*) Includes all variants

As described in attached documentation is in conformity with:

The Machinery Directive 2006/42/EC by complying to following
harmonised standard: EN ISO 3691-5:2014 and EN 16307-5:2013

Name: Wirenhammar
First name: Sven
Position: Vice President, Division Hand Trucks

Mjölby, Apr 13, 2015
Place, date of issue

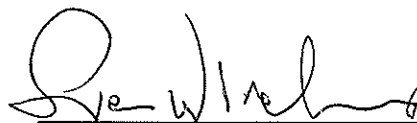
Signature

BT Products AB
SE-595 81 MJÖLBY
Sweden
Phone int.: +46 142 860 00
Org. no: 556198-2868

The Product Development Department on the address above is authorised to compile the Technical file for the products for which this certificate is valid. For deliveries to countries outside the European Union, differences may occur with regard to requirements for documentation in the local language



English