

LIFT-RITE®

LEC 2000 SC/ SCQ

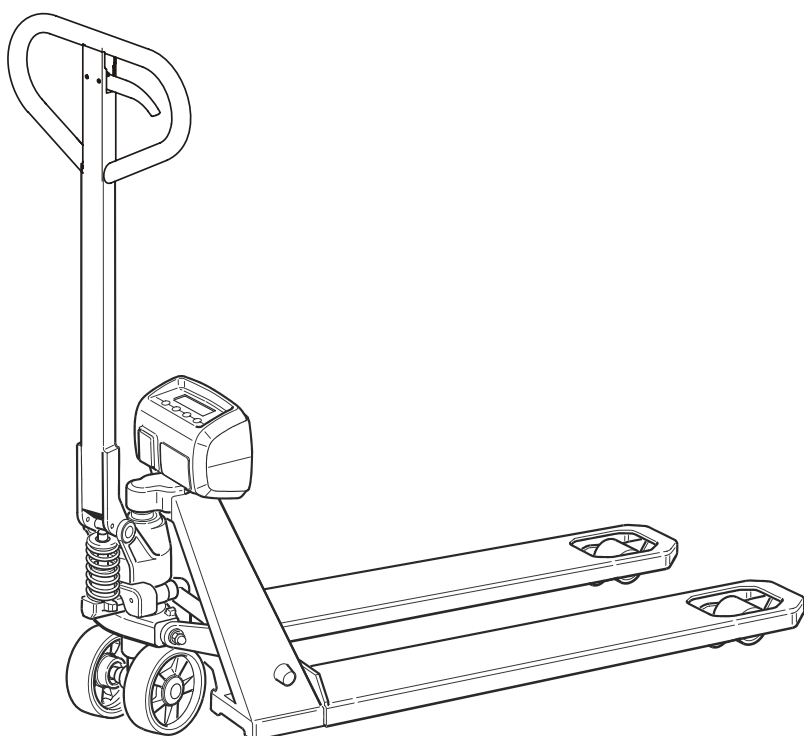

Hand Pallet Truck with scale

Operator's Manual/Service

en

Transpallettes avec balance

Manuel de instrucciones/Servicio

fr

Transpaletas Manuales con báscula

Manuale di Istruzioni/Servizio

es

Spare Parts Catalogue

Valid from serial number:

Order number: 242484-017

Issued: 2006-12-22

LIFT-RITE

	Page
Operator's Manual/Service	3 - 34
Manuel d'instructions/Entretien	
Manual de instrucciones/Mantenimiento	
Spare Parts Catalogue	

Hand Pallet Truck with scale

Operator's Manual/Service

en



WARNING!

Do not use the truck before first reading through the OPERATOR'S MANUAL.

NOTE!

Keep for future reference.



DANGER!

DANGER!

Warns that an accident **will** occur if you do not follow the instructions.

The consequences are serious personal injury or possibly death and/or extremely large material damage.



WARNING!

WARNING!

Warns that an accident **can** occur if you do not follow the instructions.

The consequences are serious personal injury or possibly death and/or extremely large material damage.



CAUTION!

CAUTION!

Warns that an accident **can** occur if the instructions are not followed.

The consequences are personal injury and/or material damage.

NOTE!

NOTE!

Marks the risk of damage of the truck if the instructions are not followed.

It is important that you read this Operator's Manual for your own safety!

Before you start to use this truck it is of extreme importance that you have **read** the contents of the entire Operator's Manual to be able to use the truck in a **safe** and **efficient** manner.

This Operator's Manual contains information on how you should use the truck, safety regulations and how to keep the truck in a safe condition by following daily service routines.

Always follow the warnings given in this Operator's Manual and on the truck to avoid accidents and incidents from occurring.

Lift-Rite Europe GmbH

Safety regulations



SAFETY SHOES

Always wear safety shoes when working with the truck.



PROTECTIVE GLASSES

Always wear protective glasses when assembling or dismantling the truck to avoid personal injury.

Control

The truck must not be used if it is damaged or has faults that affect safety or its safe use. The truck may not be used if it has been repaired, modified or adjusted unless it has been checked and approved by authorised personnel.

Operating the truck

The truck may be used only on a firm and even surface, such as concrete or asphalt.

It is not permitted to use the truck:

- In areas where the atmosphere contains gases that can cause fires or explosions.
- To transport/lift passengers.
- In cold stores or salty and other corrosive environments.

Operator's responsibility

- The truck shall only be driven with care, good judgement and in a responsible manner.
- The truck should **not** be driven with oily hands or oily shoes due to the risk of slipping.



ATTENTION!

The operator must not wear loose objects or jewellery when operating the truck.

Working area

- Ensure that the floor where the truck is to be used has sufficient load bearing capacity for the total weight of the truck including the maximum load.
- Take special care if there are protruding parts from racks, shelves or walls that can cause injury or damage the truck.
- It is **prohibited** for persons to be present in the area around the truck when there is a risk of personal injury, e.g. areas that can be reached by falling goods, lowering load handling devices or in the truck's manoeuvring area.

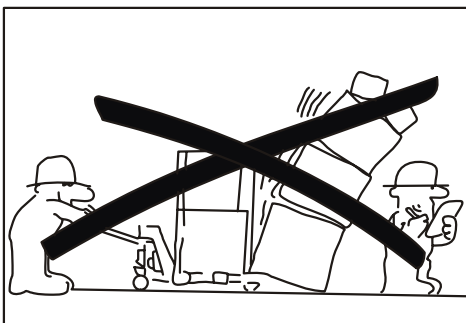

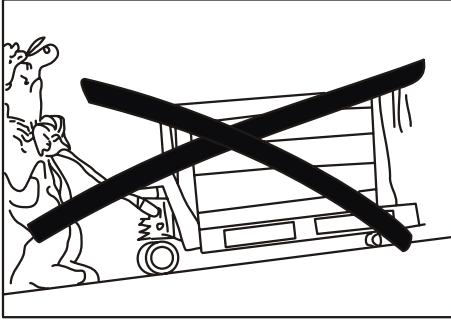

Operating and conduct while operating

- Avoid cornering at high speed.
- Pay particular attention to other personnel as well as fixed and moving objects within the working area and thereby avoid accidents.
- When the load impairs the line of vision, always drive with the load to the rear.



CAUTION!

When operating on inclines the truck shall be operated with the load downwards in the direction of the incline and driven with extreme care.



CAUTION!

Adapt the speed according to the incline and surface.



WARNING!

Risk of overturning.

A loaded truck can overturn when attempting to turn on an incline.

Never turn a loaded truck when driving on an incline.

- Always keep a safe distance from the edges of loading bays and loading ramps. Be attentive to marked risk areas.
- Before the truck is driven on to a loading ramp ensure that the ramp is correctly secured and has the necessary load bearing capacity. Drive slowly and carefully across the ramp.
- Before the truck is driven into a lift, the operator must make sure the lift is approved for the total weight of the truck, the load, operator, and any other passengers in the lift. When entering the lift, the load must enter first, not the driver. No other personnel should be in the lift when the load or truck enters or leaves the lift.
- Any accidents that have caused personal injury or damage to buildings or equipment must be reported to the supervisor. Incidents and faults on the truck shall also be reported.

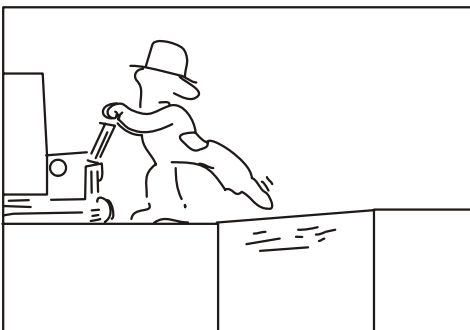

Handling loads

The weight of the load must be within the truck's permitted lifting capacity, see the truck's identification plate.

NOTE!

If a plate is unreadable a new plate must be ordered.

The length/width of the forks should be adapted to the load's shape and dimensions.

Safety regulations

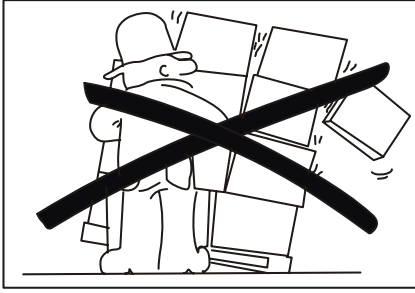

- Only handle loads that are stable and arranged in a safe manner.



WARNING!

Risk of toppling.

When handling loads stacked high, the truck can topple over and cause damage.

Exercise extreme caution when driving with high loads.



WARNING!

The truck must only be used to carry goods.

It is prohibited to use the truck for personal transport and consequently, prohibited to use the truck as a "scooter".



WARNING!

Risk of crushing under forks.

The risk of crushing can occur when lowering or by a defect in the hydraulic system and accidental lowering.

Be attentive to the risks of crushing and ensure that other persons are not in the immediate vicinity of the truck.

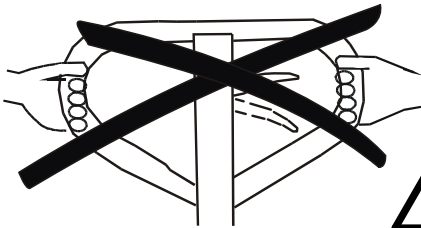

CAUTION!

Risk of crushing.

If the hands are placed on the outside of the handle, there is a risk of crushing in narrow spaces. There is also a risk of crushing if hands are kept between the tow bar and the tow bar bracket, or between the top cap and the top nut.

Because of this, be sure to keep the hands only on the top of the handle when operating the truck.

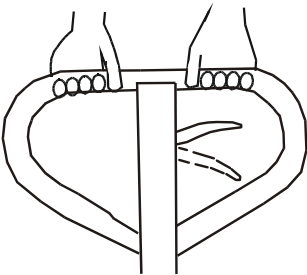

Parking the truck

- Lower the forks fully to the floor.
- **Never** park the truck on an incline.
- **Never** park the truck so that it obstructs emergency exits.
- **Never** park the truck so that it obstructs traffic or work.

Presentation of the truck

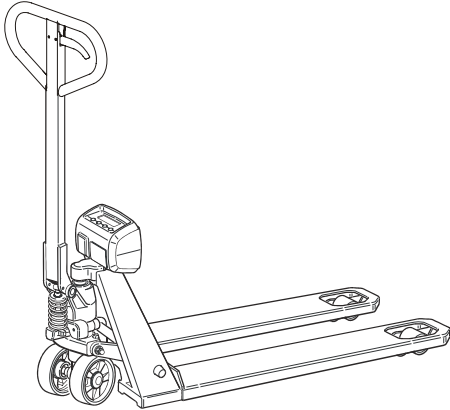

The LEC 2000 SC is a hand pallet truck with an integrated scale. Thanks to the highly precise scale, it is now possible to weigh pallets and containers at the moment of transport. To prevent errors and increase the efficiency of the logistics process, the flow of materials can be verified by weighing goods.

The LEC 2000 SCQ is designed for users with a high pallet turn-over. The forks reach the pallet surface already at the first stroke of the handle and lift the pallet during the second stroke.

The truck has a maximum lifting capacity of 2000 kg/4500 lbs.

Intended application of the truck

The truck may be used only on a firm and even surface, such as concrete or asphalt.

The truck is ideal for use in the following applications:

- To determine the exact weight of goods.
- To prevent overloading lorries.
- To verify the weight of delivered goods.
- To determine the price of goods based on its weight.

Truck data

The table provides information regarding some technical data, which is of value with daily use of the truck.

Truck type	LEC 2000 SC
Rated capacity, kg/lbs	2000/4500
Lift height, mm	205
Weight, kg	105
Turning radius (Wa), mm	1405
Permitted drive wheel, material	Nylon Polyurethan Powerthan Gummi

Presentation of the truck

Dimensions		
x	Front axle for back of fork	970 mm
y	Wheel base	1220 mm
h_3	Lift height	205 mm
h_{14}	Handle height in neutral mode	1220 mm
h_{13}	Height above lowered fork	90 mm
l_2	Truck length including back of fork	370 mm
b_1	Chassis width	520 / 685 mm
s	Fork thickness	65 mm
e	Fork width	170 mm
l	Fork length	1150 mm
b_5	Width over fork	540 / 700 mm
m_2	Ground clearance, centre of wheel base	25 mm
A_{st}	Aisle width requirement, min. Pallet size 800x1200 mm	1770 mm
W_a	Turning radius	1405 mm

Scale

General

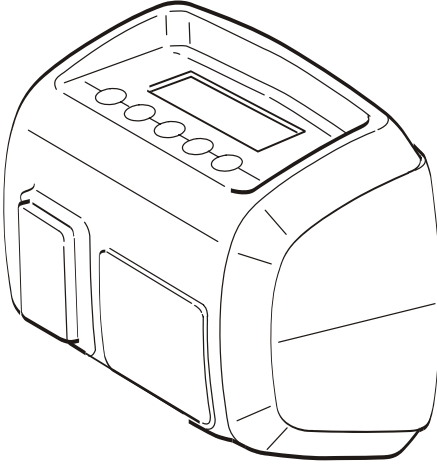

The LEC 2000 SC is a hand pallet truck with an integrated scale.

In ambient temperatures of -10 to +40°C, maximum deviation of the weighed goods is 0.1%. Outside this temperature range, the deviation may reach 0.3%.

To prevent water condensing in electronic components, avoid sudden temperature variations. If the truck is exposed to extreme temperature variations, switch off the electronics beforehand and allow it to become acclimatised.

All components have been designed for mobile use, implying a compact design and high resistance against impacts and vibration.

If inclined by more than 2°, the precision of the scale will be reduced by approx. 0.1% for each additional degree. This effect also occurs if the truck sits in a hole in the floor. Use the truck on level, even ground.

Switching on the scale

- Depress the On/Off switch (ⓐ) to switch on the scale. Wait three to five minutes until the scale electronics and the load cells have reached working temperature. If used before this, scale deviation will be around 0.3%.
- Prior to using the scale, make sure there is sufficient free space around the truck and that it is unloaded. The display features automatic zero adjustment, which means that small deviations from the zero position are corrected automatically. If the display does not correct the zero position automatically, then perform this procedure manually by pressing the →0/T← button.

Application

The scale is powered by a replaceable battery module. With a fully charged battery module, it is possible to perform weighing non-stop for approx. 35 hours (system without printer).

When the charge level of the battery module becomes low, the indication "LO-BA" is displayed. When the battery has been completely drained, the display shuts off automatically.

It is recommended to charge the battery for at least 6 hours. This will prevent deterioration of the battery capacity.

If the system is used in shift work and when expanded with a built-in printer, it is recommended to obtain a spare battery module.

Scale

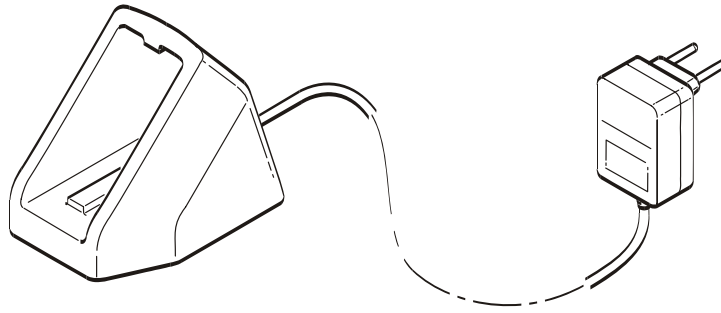

- Charge the battery module using the supplied charger. The charger LED lights during battery charging. When the LED goes out, the battery has been fully charged. Overcharging the battery is not possible since the charger switches off automatically.
- Make sure the goods does not come into contact with the display housing or other pallets.

Weighing will be more precise when the goods is placed in the centre of forks. If the load is placed off-centre, the forks can bend and twist causing deviations in the weight result.

Display



There are three display-modes.





The display may show the weight in kg's, lb's or it shows the number of pieces. Also the battery sign is integrated in the display in order to show low battery status.

By means of nine pointer bars the display shows:

~	◀	Scale read-out (incl. load) is stable
	-	The indicated value is a negative weight
ZERO	◀	The weight shown is within the zero range
NET	◀	The indicated value is the net weight
e1	▼	Displayed weight shown is in range 1
e2	▼	Displayed weight shown is in range 2
e3	▼	Displayed weight shown is in range 3
stp1	▼	setpoint 1 is activated
stp2	▼	setpoint 2 is activated

Operation buttons

Each button has two operation modes and one entry mode.

Symbol	Function level 1 (short key press)	Function level 2 (long key press)	Function level 3 (entry mode)
	Zero setting	Code entry	Enter
	Automatic tare	Pre-set tare	Decrease the value of the digit flashing
	Print weight and add to the total	Check subtotal and print total	Increase the value of the digit flashing
	Sampling a piece weight	Enter a piece weight	Shift to the next digit on the left
	On/off switch	Toggle units	Clear entry

NOTE:

Operation is only possible when the load has been firmly placed on the forks (and the "Load Stable" pointer lights up).

Error messages

Displayed error	Meaning	Out of error mode
Err01	Load cell signal is unstable	Automatic
Err02	Overload on full weighing system	Automatic after removing weight
Err03	Gross negative. This action is not allowed	Automatic
Err04	Out of zero range	Press any key
Err05	Sampling accuracy too low	Press any key
Err06	Input signal too high	Automatic after correcting input
Err07	Input signal too low	Automatic after correcting input
Err08	Calibration out of range (negative)	Automatic
Err09	Calibration out of range (signal too low)	Automatic
Err10	Calibration count 2nd (3rd) point lower than count 1st (2nd) point	Automatic
Err11	Calibration from within piece counting mode	Automatic
Err14	Setpoint value 2 < setpoint value 1. This is not allowed.	Automatic
Err97	Calibration locked (jumper JP1 placed)	Automatic
Err98	Calibration point must be higher than previous one	Automatic
Err99	Action only allowed in start-up units (kg/lb)	Automatic



WARNING!

Overload.

If the weighed load exceeds the maximum weight, the message "Err02" is displayed.

Immediately unload the truck to prevent damage to the display and the load cells.

Display messages

Text printed out	Text in display	Function
Err00	Err 00	Display error message
AddEd	AddEd	Display the word added
Add10	Add 10	Display the value to add
Adj08	Adj 08	Display adjusting cycle
TarE	TarE	Display the word tare
DonE	donE	Display the word done
PA 00	PA 00	Display the parameter number
StoP	StoP	Display the word stop
ho 00	ho 00	Display the settings for hours
m 00	m 00	Display the settings for minutes
dA 00	dA 00	Display the settings for days
m 00	m 00	Display the settings for months
yE 00	yE 00	Display the settings for years

Display functions

Multi-range graduation

Since the possible scale error is smaller when the load is light, lighter loads can be shown in smaller graduation steps on the scale display. This means that the truck can manage different weight graduations

The weight graduation step depends on the weight of the goods:

- from 0 to 200 kg, the weight is displayed in 0.2 kg steps
- from 200 to 500 kg, the weight is displayed in 0.5 kg steps
- from 500 to 2000 kg, the weight is displayed in 1 kg steps

Once a load has been weighed, the indication will recommence from the smallest graduation step. The graduation step also changes when adding or removing weight from the forks. As an example, if a load of 650 kg is gradually reduced, the indication will switch to 0.5 step graduation as soon as the weight becomes less than 500 kg.

Before weighing

Before each weighing it is necessary to check whether the system is unloaded and free. The indicator is fitted with an automatic zero correction. This means that small deviations of the zero point will be corrected automatically. If the indicator does not determine the zero point automatically, it must be done manually using the **>0<** key.

Gross weighing

When the load is lifted, the display indicates the gross weight of the load.

Net weighing: Automatic tare

The indicator offers the possibility to reset tare weights to zero automatically. This way added or subtracted weights can be determined. After taring, the graduation on the display will not change.

- Perform weighing as follows:
 1. Lift the load
 2. Depress the **←→T** button.
 - "0" (zero) is displayed.
 - "NET" is displayed, indicating that the tare weight has been activated.
 3. Adding/removing net weight
 - The net weight of the weighed load is displayed.
 - When unloading, this value becomes negative.
 4. Depress the **←→T** button again, the gross weight is displayed.

Net weighing: Manual tare entry

It is possible to enter a tare weight at any time, i.e. when the truck is loaded or unloaded.

To achieve higher precision, a tare weight with smaller graduation steps can be entered in disregard of the weight of the load and the current graduation steps of the display.

- Perform weighing as follows:
 1. Depress the **→PT** button for 3 seconds.
 - The display shows the current tare value.
 - The right digit is flashing.
 2. Depress the ENTER (↵) button if the current tare value is required.

Or

1. Depress the **→PT** button for 3 seconds.
2. Depress the **^** button to go up a value or press the **v** button to go down a value until the required value is reached.
3. Depress **<** to change to the next digit.
4. Repeat this procedure until the required tare value is displayed.
5. Depress ENTER (↵) to activate the tare weight.
 - The tare weight has now been activated.
 - "NET" is displayed.
 - If the system holds a load at that moment, the net weight of the load will be displayed.
 - If no load is on the system at that moment, the display will show the entered tare value as a negative value.
 - The entered value will remain active until a new tare weight is entered (display shows the new net weight).
 - Depress the **←→T** button to return to gross weighing mode.

Code entry

The indicator offers the possibility to enter 1 numeric code of 6 digits. Entry of codes is useful when the weighing system is connected to a printer or other peripheral equipment, in order to identify various weighings during a later processing of the information.

1. Depress the **No** button for 3 seconds.
 - The display will show the last used code with the right digit flashing.
2. To accept the old value press ENTER (↵).
 - The code is activated and the display returns to the weighing mode.

Scale

Or

1. Depress the **No** button for 3 seconds.
2. Depress the \wedge button to go up a value or press the \vee button to go down a value until the required value is reached.
3. Depress \leftarrow to change to the next digit.
4. Repeat this procedure until the required code is displayed.
5. To accept the new code depress ENTER (\rightarrow).
 - The code is activated and the display returns to normal weighing mode.
You may make a printout and add up the weights. A special printout will be made which includes the code. (See option printer).

NOTE!

If the code is "000000" it will be ignored and it will not be printed on the ticket.

Piece counting: Sampling

If an unknown piece weight is to be determined you may do this by sampling a certain number of pieces. The number of pieces taken from or placed on the weighing system determines the accuracy of the sampling. The total weight of the pieces taken from or placed on the weighing system for the sampling should be no less than 4-5 kg. The greater the weight difference, the greater accuracy. The standard sampling amount is 10 pieces, but this number can be increased up to 95 pieces.

NOTE!

If the accuracy is too low when sampling, the indicator will show "ERR05". Press any key to return to piece counting mode and increase the sampling amount.

1. Depress the ⋮ button.
 - The display shows "add10". The 'kg' pointer turns off and the 'pcs' pointer goes on.
2. Take or place 10 pieces from/on the weighing system and press the ENTER (\rightarrow) key.
 - The sampling is done and the display will show the total number of pieces on the weighing system.

Or

1. Depress the \wedge button or the \vee key to change the number of pieces to add.
 - The display will show the new value to add. (for example "add50")
2. Take or place the correct number of pieces from/on the weighing system and press the ENTER (\rightarrow) key.
 - The sampling is done and the display will show the total number of pieces on the weighing system.

Scale

You may make a printout and add up the weights. A special printout will be made which includes the piece weight sampled and the number of pieces (see option printer).

To return to the normal weighing mode press the  button for 3 seconds. Once your return to normal weighing mode the piece count total will be lost.

Piece counting: Enter a piece weight



1. Depress the  button for 3 seconds.
 - The last used piece weight will be displayed with the right digit flashing.
2. To accept the old value depress ENTER (↵).
 - The display shows the number of pieces currently on the weighing system

Or

1. Depress the  button for 3 seconds.
2. Depress the ^ button to go up a value or depress the v button to go down a value until the required value is reached.
3. Depress to change to the next digit.
4. Repeat this procedure until the required piece weight is displayed.
5. To accept the new value depress ENTER (↵).
 - The display shows the number of pieces currently on the weighing system.

Adding weight results

The indicator offers the possibility to add weighings and show the total weight. When a tare weight is active, the net weight is added automatically.

1. Load the system with the weight that should be added.
2. Depress the  button to add the weighed load to the total weight.
 - The display shortly shows the message "ADDED" and then automatically returns to the weighing mode.
 - If a printer is installed, a printout will be made. The gross, net and tare weights are totalled.
 - No weight can be recorded twice. The system needs to be returned to the net zero-range before another weight can be added up.
3. The subtotal can be checked by pressing the  button for 3 seconds.
 - The display shows the net total weight and the number of weighings totalled so far repeatedly for 3 seconds.
 - If the  button is depressed shortly during this period, the total is printed out (if option is installed) and reset to 0.
 - If the "CE" button is pressed during this period, the total is reset but not printed out.
 - If no button is pressed during this period, the subtotal stays in memory and the system returns to the weighing mode after 60 seconds.

Change units

The system is set to start up in 'kgs' or in 'lbs'. However you may, at any time in the weighing mode, change to the second unit (lbókg or kgólb).

1. Depress the  button for 3 seconds.
 - The display will show the current weight in the new units for 5 seconds and then automatically change back to the start up units.

The same button is used to change from the piece counting mode back to the weighing mode.

NOTE!

It is not possible to use any of the scale functions when the display has been changed to the second unit. If any key is pressed the indicator will display "ERR99" and return to normal weighing mode.

Printer (Option)

If the weighing system has been equipped with a printer, obtained and entered weighing data can be printed. Date and time are only printed out with the option board installed.

In the printout a gross weight is indicated with the letters "**B/G**" and a net weight with the letter "**N**". A manually entered tare weight will also be printed and is indicated with the letters "**PT**". The total weight is shown with the letters "**TOT**".

Paper roll replacement

Proceed as follows to replace the paper roll:





1. Open the printer cover by pressing down the 2 levers and pulling the cover towards you.
2. Remove the existing paper roll.
3. Position the new paper roll, making sure it unrolls in the correct direction.
4. Unroll the paper slightly.
5. Re-close the cover, holding the edge of the paper. The printer is now ready for use.

Changing the time and date on the printout

If the weighing system has been equipped with a printer, and an option board, the date and time can be printed together with the weight information.

1. Depress the  button for 6 seconds.
 - The display will show "ho_00" or the previous hour time setting, with the right digit flashing.
2. To accept the old value press ENTER (↵).

Or

1. Depress the  button to go up a value or press the  button to go down a value until the required value is reached.
2. Depress  to change to the next digit and use the  or  button to change the value until the required value is reached.
3. To accept the new value press ENTER (↵).
 - The display will show "m_00" or the previous minute time setting, with the right digit flashing.
4. Repeat the above procedure to accept or change the minute setting.
 - The display will show "dA_00" or the previous date of the month setting, with the right digit flashing.
5. Repeat the above procedure to accept or change the date of the month setting.
 - The display will show "m_00" or the previous month setting, with the right digit flashing.

Scale

6. Repeat the above procedure to accept or change the month setting.
 - The display will show "YE_00" or the previous year setting, with the right digit flashing.
7. Repeat the above procedure to accept or change the year setting.

The indicator will return to normal weighing mode.

Relay (Option)

If this option is used, it is no longer possible to use 'piece-counting mode'. The setting of the set-points for the relay is done with the same key as is used for sampling or entering a piece weight.

Relay Technical Specifications: Type: Zettler AZ833-12DE
Coil voltage: 12VDC
Switched capacity:
max. 30VDC/2A

The choice of relay application is made when the system is ordered and the program is selected in the parameter menu. The instructions for use depend on the application chosen.



Four different applications are possible:

1. overload check gross weight
2. overload check net weight
3. dosing/filling with manual start
4. dosing/filling with automatic start





Overload check gross weight (1)

In this setting set-point 1 is activated as soon as the gross value exceeds the set-point value. In this case the set-point value is an absolute value.

To enter a new value:

1. Depress the  button.
 - The display shows the last entered value with the left digit blinking. The pointer for set-point 1 is on.
2. Depress  to accept the old value.
 - The set-point value is activated and the display returns to the weighing mode.



Or

1. Depress the  button.
2. Depress the  button to go up a value or press the  button to go down a value until the required value is reached.
3. Depress  to change to the next digit.
 - Repeat this procedure until the required value is displayed.
4. Depress  to accept the new value.
 - The set-point value is activated and the display returns to the weighing mode.





Overload check net weight (2)

In this setting set-point 1 is switched on as soon as the net value exceeds the set-point value. In this case the set-point value is an absolute value.

To enter a new value:

1. Depress the  button.
 - The display shows the last entered value with the left digit blinking. The pointer for set-point 1 is on.
2. Depress  to accept the old value.
 - The set-point value is activated and the display returns to the weighing mode.



Or

1. Depress the  button.
2. Depress the  button to go up a value or press the  button to go down a value until the required value is reached.
3. Depress  to change to the next digit.
 - Repeat this procedure until the required value is displayed.
4. Depress  to accept the new value.
 - The set-point value is activated and the display returns to the weighing mode.





Dosing/filling with manual start (3)

In this setting set-point 1 and 2 are switched on as soon as the tare key has been activated and after the set-point values have been entered.

To enter new set-point values:

1. Depress the  button.
 - The display shows the last entered value with the left digit blinking. The pointer for set-point 1 is on.
2. Depress  to accept the old value.
 - The value for set-point 1 is activated. The display shows the last entered value for set-point 2 with the left digit blinking. The pointer for set-point 2 is on.

Or

1. Depress the  button.
2. Depress the  button to go up a value or press the  button to go down a value until the required value is reached.
3. Depress  to change to the next digit.
 - Repeat this procedure until the required value is displayed.
4. Depress  to accept the new value.
 - The set-point value is activated and the display returns to the weighing mode.
 - The display shows "tare".

Filling:

- Place an empty container on the scale.
1. Depress the  button.
 - The display shows the net value and the pointers stp1 and stp2 are on.
 - Relays 1 and 2 are closed.
 - As soon as set-point 1 is reached, pointer stp1 will turn off and relay 1 will be opened.
 - As soon as set-point 2 is reached, pointer stp2 will turn off and relay 2 will be opened.
 - The display shows "done" for a few seconds and will return in the normal weighing mode.
 - The net weight is displayed. A printout may be made at this point.

It is possible to cancel the filling procedure at any time by pressing the CE key

Dosing:

- Place a full container on the scale.
 1. Depress the ←→T button.
 - The display shows the net value and the pointers stp1 and stp2 are on.
 - Relays 1 and 2 are closed.
 - As soon as set-point 1 is reached, pointer stp1 will turn off and relay 1 will be opened.
 - As soon as set-point 2 is reached, pointer stp2 will turn off and relay 2 will be opened.
 - The display shows "done" for a few seconds and will return in the normal weighing mode.
 - The net weight is displayed. A printout may be made at this point.

It is possible to cancel the dosing procedure at any time by pressing the CE key.



The printout will show the following:

- The gross weight is the weight of the container with rest material.
- The tare weight is the weight of the container with material before dosing.
- The net weight will show a minus sign as token of weight being removed from the scale.





Dosing/filling with automatic start (4)

In this setting set-point 1 and 2 are switched on as soon as the set-point values have been entered. The tare action is done automatically in this mode.

To enter new set-point values:

1. Depress the  button.
 - The display shows the last entered value with the left digit blinking. The pointer for set-point 1 is on.
2. Depress  to accept the old value.
 - The value for set-point 1 is activated. The display shows the last entered value for set-point 2 with the left digit blinking. The pointer for set-point 2 is on.

Or

1. Depress the  button.
2. Depress the  button to go up a value or press the  button to go down a value until the required value is reached.
3. Depress  to change to the next digit.
 - Repeat this procedure until the required value is displayed.
4. Depress  to accept the new value.
 - The set-point value is activated and the display returns to the weighing mode.
 - The display shows "tare" and the indicator automatically tares out the scale after the scale has been stable for a few seconds.

ATTENTION!

Be sure the container is already in place at this moment!

Filling and dosing:

- The display shows the net value and the pointers stp1 and stp2 are on.
- Relays 1 and 2 are closed.
- As soon as set-point 1 is reached, pointer stp1 will turn off and relay 1 will be opened.
- As soon as set-point 2 is reached, pointer stp2 will turn off and relay 2 will be opened.
- The display shows "done" for a few seconds and will return in the normal weighing mode.
- The net weight is displayed. A printout may be made at this point.

It is possible to cancel the filling or dosing procedure at any time by pressing the CE key.

The printout will show the following:

- The gross weight is the weight of the container with rest material.
- The tare weight is the weight of the container with material before dosing.
- The net weight will show a minus sign as token of weight being removed from the scale.

Cancelling the dosing or filling

It is possible to cancel the filling or dosing procedure at any time by pressing the CE key.

1. Depress the CE key to stop the procedure.
 - The display shows "Stop" and the relays are opened. Pointers Stp1 and Stp2 will be turned off.
2. Depress ENTER to start the procedure again.
 - The display sign "Stop" is cleared and the net weight is displayed again. The relays are closed. Pointers Stp1 and/or Stp2 will be turned on.

Or

1. Depress the CE key to stop the procedure.
 - The display shows "done" for a few seconds and will return in the normal weighing mode.
 - The net weight is displayed.

Daily service and function checks

- The operator is responsible for the daily service and care of the truck.
- Carry out the daily service at the start of the working day or shift, before the truck is used. The daily service is a function control as set out in the checklist below.

Check points	Action
Steering	Check its function
Scale	Check its function
Hydraulic system	Check the oil level/ oil leakage
Wheels	Check for damage, remove oil, metal chips and the like
Chassis	Check for damage, remove dirt and the like
Lifting/lowering	Check the function of lift/neutral/lower positions
Signs	Check the readability



WARNING!

Never neglect the daily service and function checks. Serious accidents can occur. Always report any faults or damage to the management without delay. Never use a truck that has faults.

Only approved original spare parts shall be used with service and repairs.

It is recommended that you sign a service and maintenance agreement with your closest representative to ensure the truck's operating economy and safety.

Daily service and function checks

Troubleshooting

LEC 2000 SC Fault	Cause	Action
Pump does not take a full stroke	Air in the hydraulic system. Insufficient hydraulic oil.	Pump 5 strokes with lowering valve open. Contact a service technician.
Lift, neutral and lowering positions do not function correctly	The lowering valve is incorrectly set	Adjust the setting of the valve chain using adjuster nut
The forks drop after every stroke	Leakage from the valve cone	Replace the valve cone and washer
LEC 2000 SCQ Fault	Cause	Action
Quick lift does not work	Ball valve leakage	Replace the quick rod

Maintenance

- To prevent malfunctions and accidents, be sure to perform regular maintenance on the truck according to the *Lubrication diagram* (page 32). Only qualified service technicians with the necessary knowledge are allowed to adjust and repair the truck.

All replacement parts should be approved spare parts.

Modifications or conversions to the truck that affect the safe use or function are not permitted.

Safety regulations with maintenance work

- Keep the area where you carry out the service clean. Oil or water makes the floor slippery.

NOTE!

Extreme cleanliness should be observed at all times when working with the hydraulics. Dismantled parts should be clean and inspected carefully. Always replace gaskets after dismantling.

- Store and dispose of changed oil in accordance with local directives.
- Do not release solvents and the like, which are used for cleaning/washing, into drains that are not intended for this purpose. Follow the local directives that apply for disposal.
- Remove at least 100 mm (4") of paint around the welding/grinding area through sand-blasting or the use of a paint stripper when welding or grinding on painted surfaces.



CAUTION!

Harmful gases.

Paint that is heated gives off harmful gases. Remove 100 mm of paint around the working area.



WARNING!

Risk of crushing.

An improperly supported truck could fall down.

Be sure to securely support the truck during all repair work.

Cleaning and washing

Cleaning and washing of the truck is important to ensure the truck's reliability.

- Do not use a high pressure cleaning equipment on the scale parts at any time.
- Carry out general cleaning and washing weekly.
- Always rinse the truck with plentiful of water each time it has been cleaned.
- Always lubricate the truck after washing according to the lubrication diagram and table.

Maintenance

Lubrication diagram

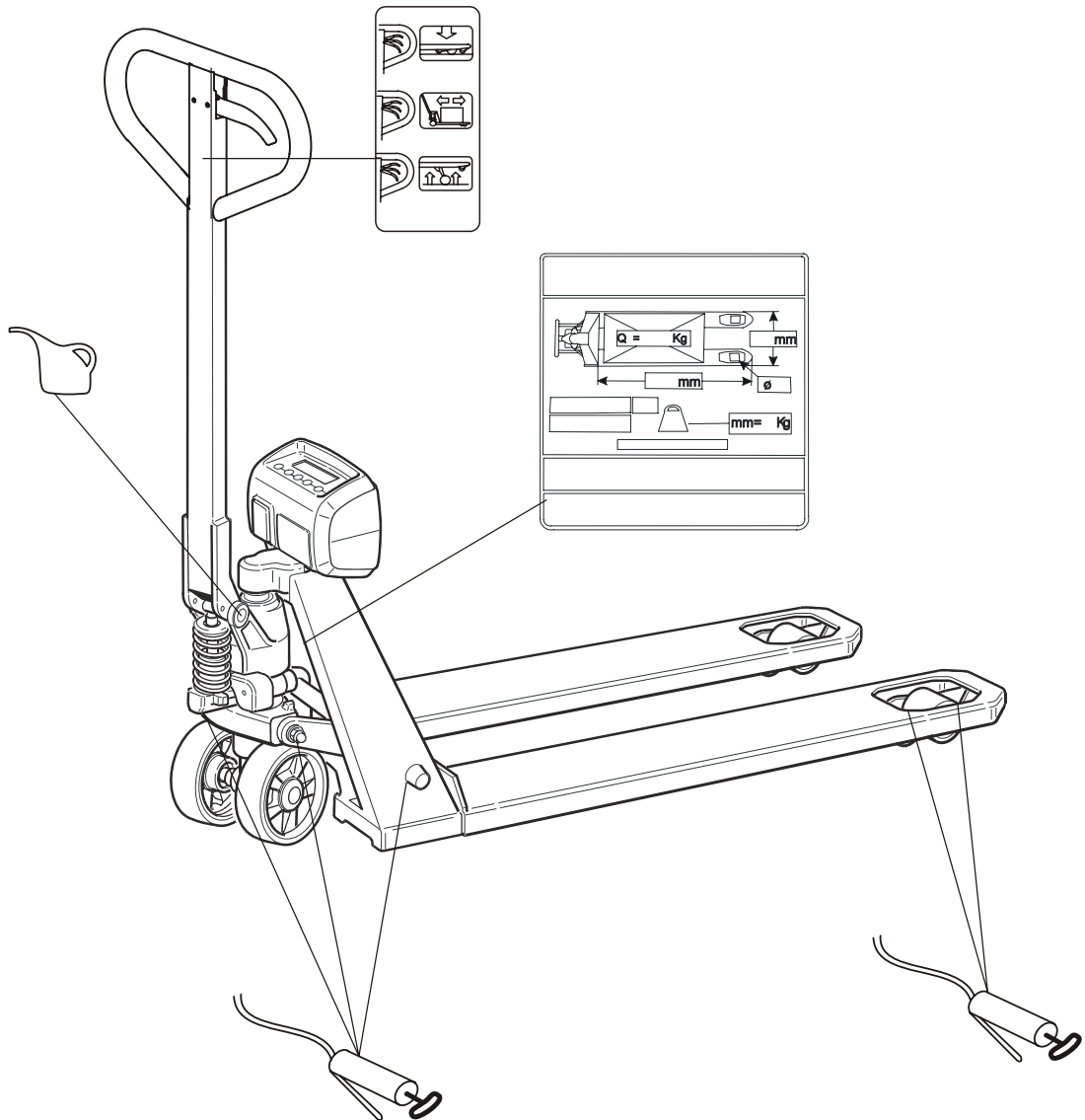

Oil and grease specification			
Lubricant	Specification	Product name	Order No.
Grease		OKQ8 Rubens WB	213366
Hydraulic oil >-15° C	ISO-VG32 Quality level: ISO 6743-4 category HM DIN 51524 part 2 category HLP	Hydraulic oil 32	1 litre: 233328-001 5 litres: 233328-002
Hydraulic oil <-15° C	ISO-VG27,5 Quality level: ISO 6743-4 category HV DIN 51524 part 3 category HVLP	Statoil 131	1 litre: 233916-001 5 litres: 233916-002

Lifting the truck

- Lift with the greatest of care.



WARNING!

Risk of cutting.

There is a risk of cutting when the truck is lifted by hand and holding it by the forks and the end plate.

Always use work gloves when lifting by hand.



WARNING!

Risk of crushing.

There is a risk of crushing when the truck is lifted by hand and holding it by the hydraulics body.

Always use work gloves when lifting by hand.

Recycling/discarding



The truck consists of parts that contain recyclable metals and plastics. Below is a list of those materials used in the truck's sub-systems.

Chassis	
Frame	Steel
Wheel suspension	Steel and cast iron
Bushings	Brass
Grease nipples	Aluminium
Wheels	Nylon, Polyurethane, Powerthan, rubber
Finish	Epoxy-polyester

Hydraulic system	
Frame	Steel
Pressure plate	Cast iron
Tow bar	Steel and nylon
Wheels	Nylon, Polyurethane, Powerthan, rubber
Finish	Epoxy-polyester
Bushings	Brass
Hydraulic oil	Disposal acc. to local directives
Top nut	Aluminium
Assembly parts	Steel, aluminium, brass, rubber, polyurethane, nylon

Weighing system	
Housing indicator	Plastic
Load cells	Steel
Cables	Copper cores with PVC sheaths
Electronic board	Reinforced glass fibre circuit board laminate