

EDGE

LITHIUM-ION MOTORIZED PALLET TRUCK

GIVE YOURSELF THE EDGE IN PRODUCTIVITY AND AFFORDABILITY

The *Edge* is a Lithium-Ion powered pallet jack offering exceptional durability, maneuverability, and affordability. With a compact design and motorized lift, lower, and travel capabilities, the *Edge* allows operators to effortlessly handle loads up to 3,300 lbs. in even the most confined spaces. Add in fast charging, and simple battery changes, and it's easy to see how the *Edge* gives you a productivity edge over manual hand pallet jacks.



LIFFRITE
KEEPS YOU MOVING

EDGE

LITHIUM-ION MOTORIZED HAND PALLET TRUCK

EASY TO USE

Simple, easy to use electric lift, lower, and travel controls increase operator productivity.

EASY TO HANDLE

Compact design and pinwheeling capability allows easy handling in narrow aisles, doorways, elevators, and other tight spaces.

EASY TO AFFORD

The lithium-ion Edge is competitively priced, suitable for multiple applications, and in stock for immediate delivery.

IDEAL FOR:

- » Retail
- » Delivery
- » Dock Work (Shipping/Receiving)
- » Warehousing
- » Trailers
- » Mezzanines
- » Elevators



Long run times ensure efficient use of trucks and operators



Quick, easy battery changes optimize uptime and productivity



Fast and opportunity charging using a standard 110V outlet minimizes downtime

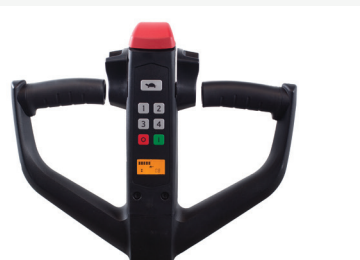

Key pad access prevents unauthorized use for enhanced security

STANDARD SPECIFICATIONS:

- » Capacity: 3,300 lbs.
- » Available batteries: (24 volt / 20Ah or 24 volt / 36Ah)
- » External charger: 8A or 12A (12A for 36Ah battery only)
- » Travel speed: 2.8-3.0 mph
- » Lift height: 7.7"
- » Lowered height: 3.2"
- » Fork length: 45.3"
- » Fork overall width (OAW): 27"

Not for use in cold storage applications.

AVAILABLE OPTIONS:

- » 48" Load Backrest
- » Extra batteries 20Ah & 30Ah
- » Casters

PRODUCT	PART NUMBER
27X45 EDGE 8A/20AH	1370577-101
27X45 EDGE 8A/20AH, CASTERS	1370577-102
27X45 EDGE 12A/36AH	1370577-103
27X45 EDGE 12A/36AH, CASTERS	1370577-104
EXTRA 20AH LIB	1370531-001
EXTRA 36AH LIB	1370531-002
48" LOAD BACKREST	1370532-002

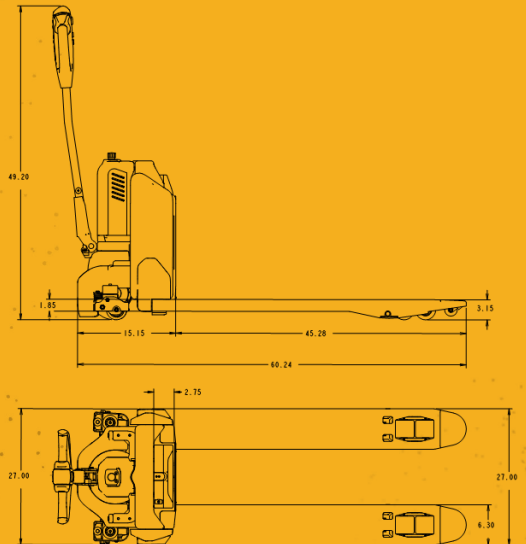

**CONTACT US AT
1-800-558-6012 FOR
MORE INFORMATION OR
TO ORDER TODAY!**

LIFT-RITE
KEEPS YOU MOVING

©2020 Lift-Rite

PO Box 130, Greene, NY 13778-0130
www.lifrite.com | Toll free 1-800-558-6012

Due to continuous product improvement, specifications are subject to change without notice or obligation. Some systems and features shown are optional at extra cost. Lift-Rite is a U.S. trademark of Lift-Rite.