

EDGE STACKER

LITHIUM-ION-POWERED WALKIE STACKER

MOVE AND STACK PALLETS MORE QUICKLY AND EASILY.

Ideal for light-duty applications, the 2,600 lb. capacity, lithium-ion-powered Lift-Rite Edge Stacker gives you a highly maneuverable, productive stacker capable of lifting loads as high as 140".

User and application friendly, the Edge Stacker features electric lift, lower, and travel to increase operator productivity, as well as adjustable base legs to suit multiple pallet sizes and aisle widths.

COMMON OPERATIONS:

WAREHOUSING
DISTRIBUTION
HOME CENTERS
RETAIL/GROCERY STORES
AUTO PARTS



LIFFRITE
KEEPS YOU MOVING

EDGE STACKER

LITHIUM-ION-POWERED WALKIE STACKER

SUPERIOR PRODUCTIVITY

- » Electric travel, lift, and lower enhance productivity.
- » Lithium-ion battery offers fast charging and long run times.

BETTER MANEUVERABILITY

- » Turtle Speed Button simplifies handling in tight spaces.
- » Creep mode allows travel with handle in vertical position.

GREATER SECURITY

- » Reduced speed in turns minimizes truck, product, and facility damage.
- » Load backrest (standard) enhances load stability and handling.

IDEAL FOR:

- » LIGHT-DUTY GENERAL MATERIAL HANDLING
- » STACKING
- » PALLET HANDLING IN TIGHT AREAS



Opportunity charging keeps the trucks on the floor



Dual thumb controls offer comfortable operation for left- or right-handed users



PIN code access requires no key and prevents unauthorized use

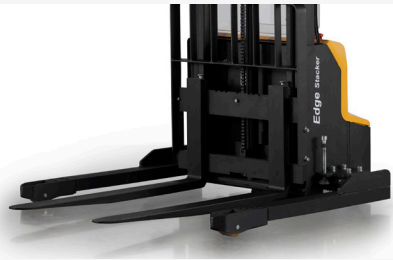

Adjustable base legs suit multiple pallet sizes.

STANDARD SPECIFICATIONS:

- » 2,600 lb. capacity
(2,200 lb. over 126" lift height)
- » 24V/60Ah LIB
- » Travel speed: 2.6 - 2.8 mph
- » Run time: ~2 hrs
- » DC motor
- » Mast configurations:
76"/112" two stage, no free lift
90"/140" two stage, no free lift
- » Turning radius: 53"
- » Base leg widths (outside):
46.5", 50.5", 54.5", 58.5"

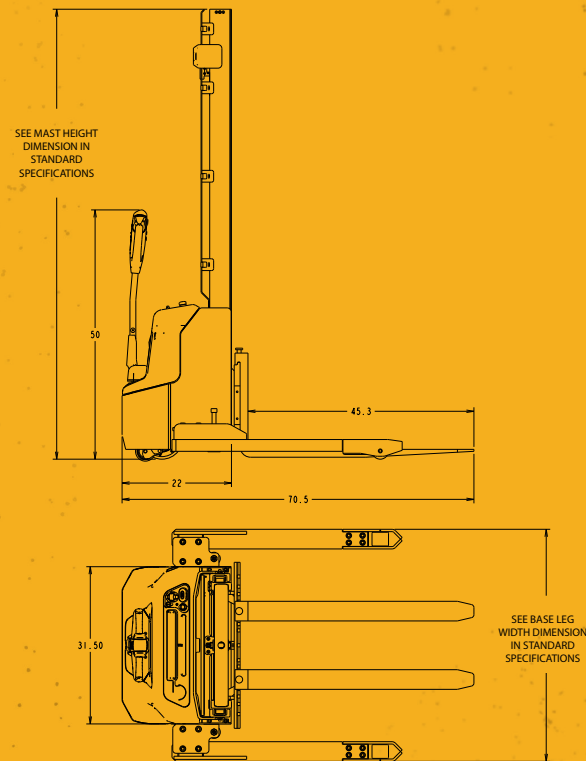

**FOR ORDERS OR INQUIRIES,
CALL 1-800-558-6012
OR EMAIL HPTORDERS@LIFTRITE.COM**

LIFTRITE
KEEPS YOU MOVING

Due to continuous product improvement, specifications are subject to change without notice or obligation. Some systems and features shown are optional at extra cost. Lift-Rite is a U.S. trademark of Lift-Rite.

©2020 Lift-Rite
PO Box 130, Greene, NY 13778-0130
www.lifrite.com | Toll free 1-800-558-6012
LR-1000 222